

## Quick Installation Guide for OACIS-1XC

# OACIS

Open Architecture Control Integrated System

Version 02.03



SERVO PRESS | NUT RUNNER | DAQ & ANALYSIS | SPC

# Package Contents

|  | S/N | EA | CHECK                    |
|--|-----|----|--------------------------|
| <b>● OACIS-P</b>                       |     |    |                          |
| 01. Servo Press                        |     |    | <input type="checkbox"/> |
| 02. Servo Drive                        |     |    | <input type="checkbox"/> |
| 03. Interface SGA-D Signal Conditioner |     |    | <input type="checkbox"/> |
| 04. Power Cable                        |     |    | <input type="checkbox"/> |
| 05. Brake Cable                        |     |    | <input type="checkbox"/> |
| 06. Motor Encoder Cable                |     |    | <input type="checkbox"/> |
| 07. CN1 Cable                          |     |    | <input type="checkbox"/> |
| 08. Limit Sensor Cables                |     |    | <input type="checkbox"/> |
| 09. STO Cable                          |     |    | <input type="checkbox"/> |
| <b>● OACIS-T</b>                       |     |    |                          |
| 10. Nut Runner                         |     |    | <input type="checkbox"/> |
| 11. Servo Drive                        |     |    | <input type="checkbox"/> |
| 12. Interface SGA-D Signal Conditioner |     |    | <input type="checkbox"/> |
| 13. Power Cable                        |     |    | <input type="checkbox"/> |
| 14. Brake Cable                        |     |    | <input type="checkbox"/> |
| 15. Motor Encoder Cable                |     |    | <input type="checkbox"/> |
| 16. CN1 Cable                          |     |    | <input type="checkbox"/> |
| 17. STO Cable                          |     |    | <input type="checkbox"/> |
| <b>● SERVO CONTROLLER</b>              |     |    |                          |
| 18. OACIS-1XC                          |     |    | <input type="checkbox"/> |
| 19. Firmware Download Cable            |     |    | <input type="checkbox"/> |
| <b>● ETC</b>                           |     |    |                          |
| 20. Quick Installation Guide           |     |    | <input type="checkbox"/> |
| 21. USB with Setup Software            |     |    | <input type="checkbox"/> |
| 22. User Manual Book                   |     |    | <input type="checkbox"/> |
| 23. Origin of Certificate              |     |    | <input type="checkbox"/> |

# Quick Installation Diagram

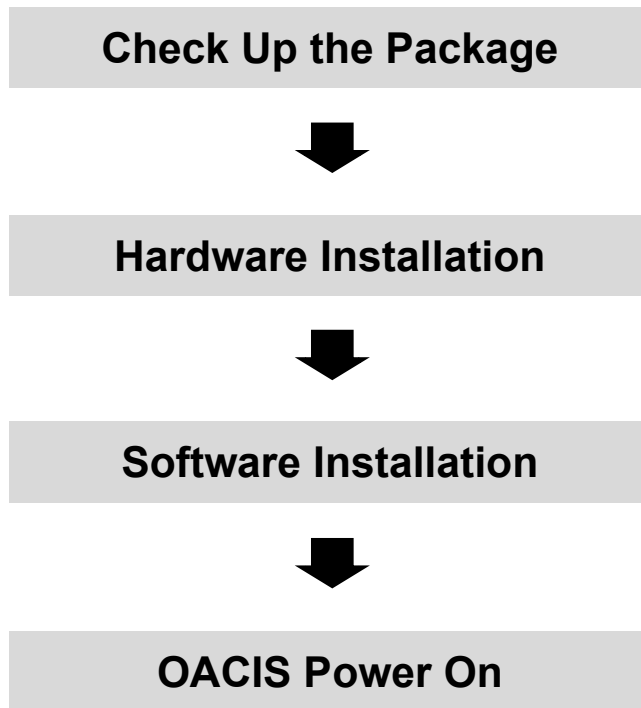



## I. Check up the Package

### Case I. One Servo Press with OACIS-1XC

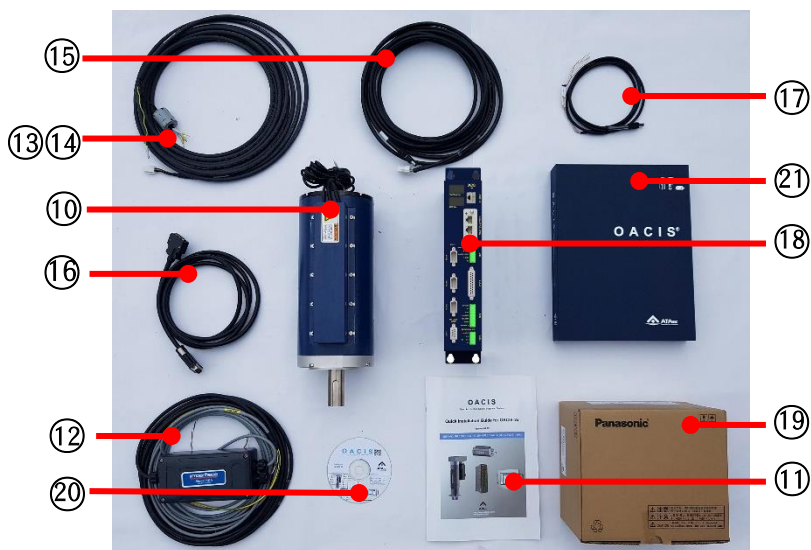

### Case II. One Nut Runner with OACIS-1XC



 These pictures can be different from the real one.  
Numbering of Products refer to page 2.



**DO NOT CONNECT ALL THE CABLES WITH POWER ON.**

All the wirings should be connected after switch off.

Otherwise severe damage for the devices might happen.

## II. Hardware Installation

### A. Connect OACIS Power In & Ground

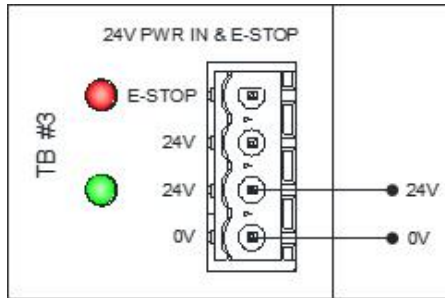

- ✓ It is recommended to separate Power In Connection from frequent Turn On and Off circuit like Light Curtain

### B. Connect Analog Inputs

- ✓ Each Analog Input Channel has its own GND terminal.
- ✓ Signal Type Selection Switch (ONLY AI#5, 6) needs to be set properly per the input signal type.
  - Allowable Signal Range with Input Setting

| Voltage Input | Current Input |
|---------------|---------------|
| ±10V          | 4~20mA        |

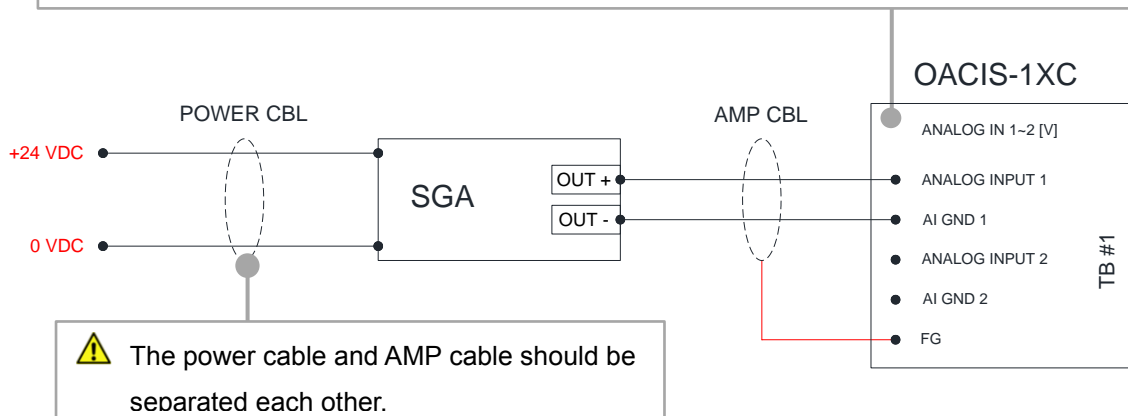

- ⚠ Over current or voltage input may cause severe damage to OACIS.
- ⚠ The Analog Inputs should be wired to OACIS AI channels directly not through any other Terminal Blocks.



- ✓ Keep the encoder cable away from the power cable wiring by **300 mm or more**.
- ✓ Do not guide the encoder cable through the same duct as the power cable, nor bind them together.

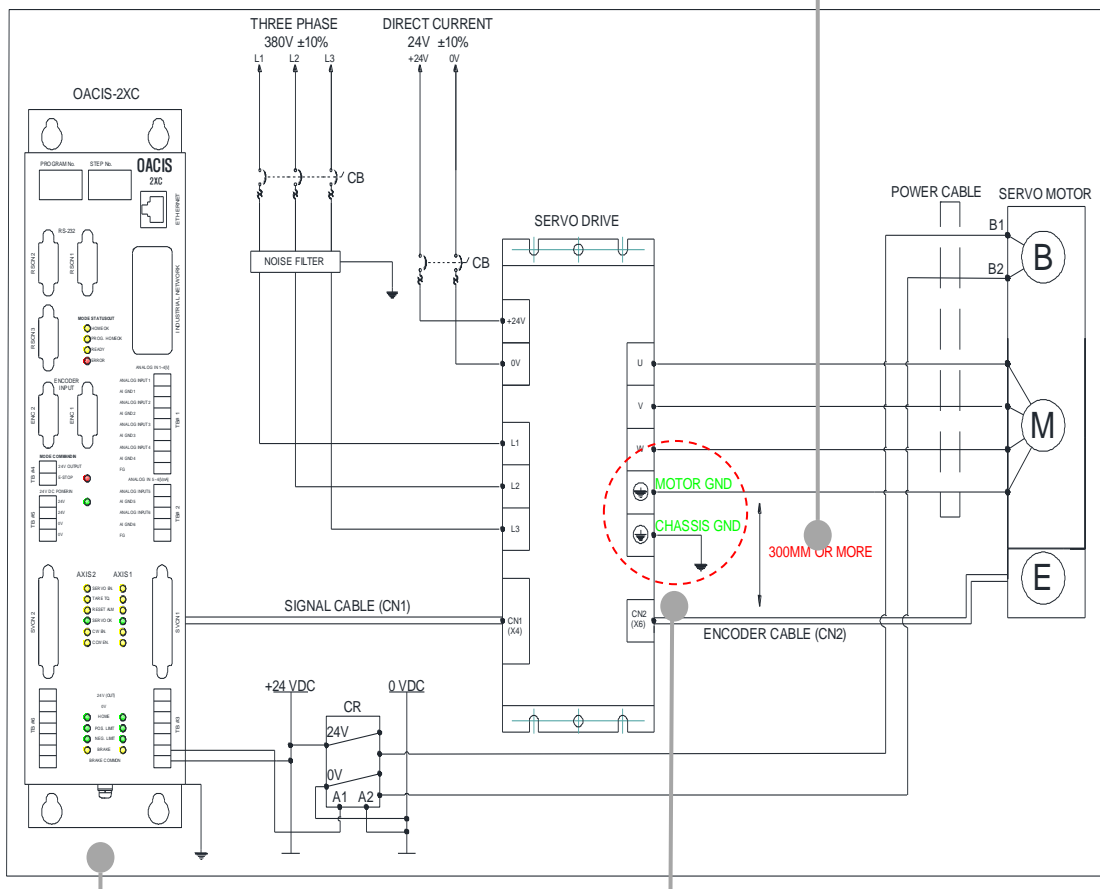

- ✓ There are two ground terminals provided on the driver. One of them must be connected to **the ground terminal of control panel** and the other is for **the motor ground**.

- ✓ Check up the OACIS Ground Connection at the bottom of OACIS.

- ⚠ Make sure that your Circuit breaker for Servo Motor and Drive is set properly. Different Servo Motor requires different circuit.
- ⚠ The ground terminal must not be shared with other equipment.
- ⚠ Overall pay particular attention to wiring especially in power input and motor output, ground of loose connection.

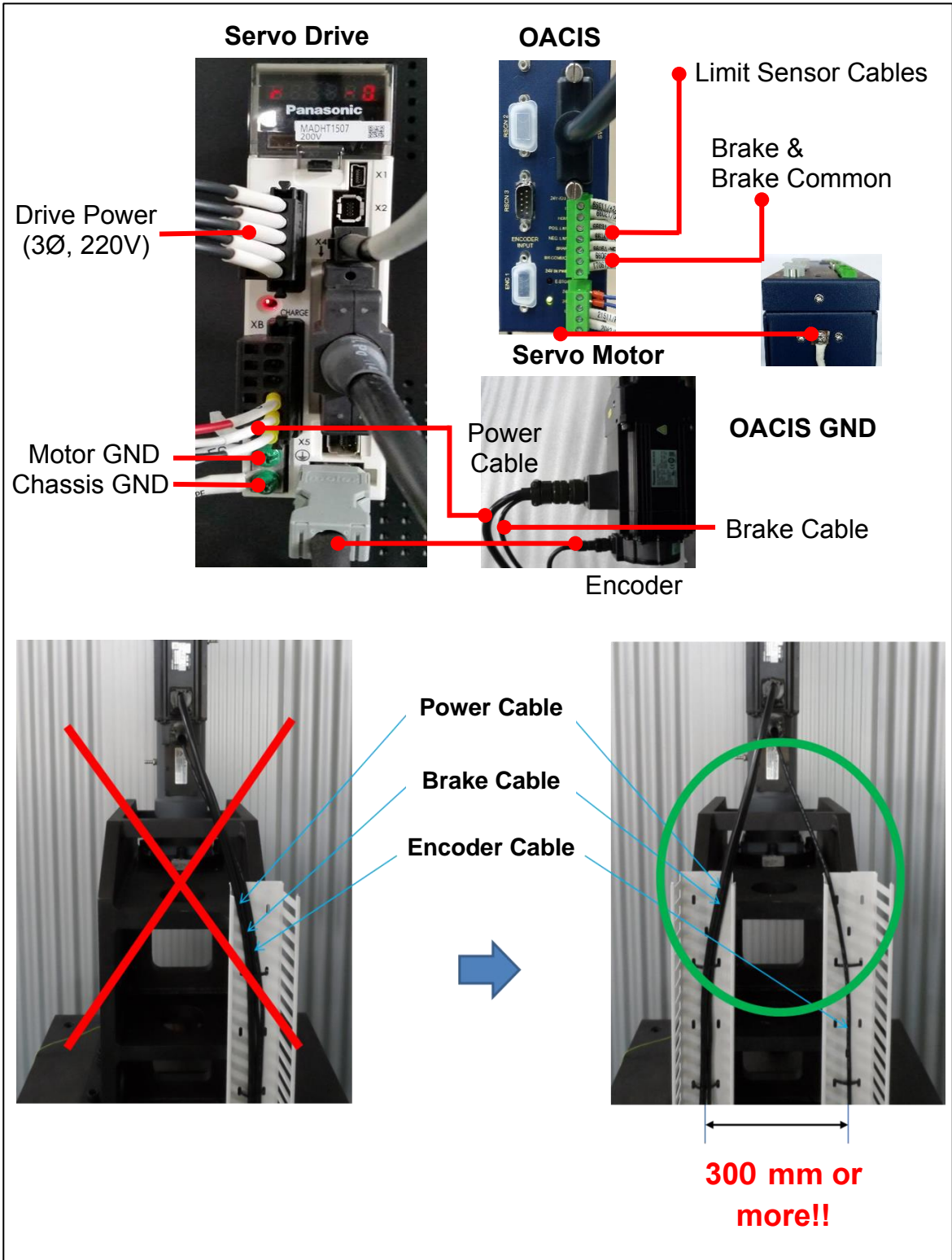

## E. Safety Circuits

- ✓ The circuits should meet ISO standard safety requirement.
  - EN ISO 13849-1 / 14121-1
  - EN/IEC 61508
  - EN/IEC 62061
- ✓ Safety circuit example for Cat 3

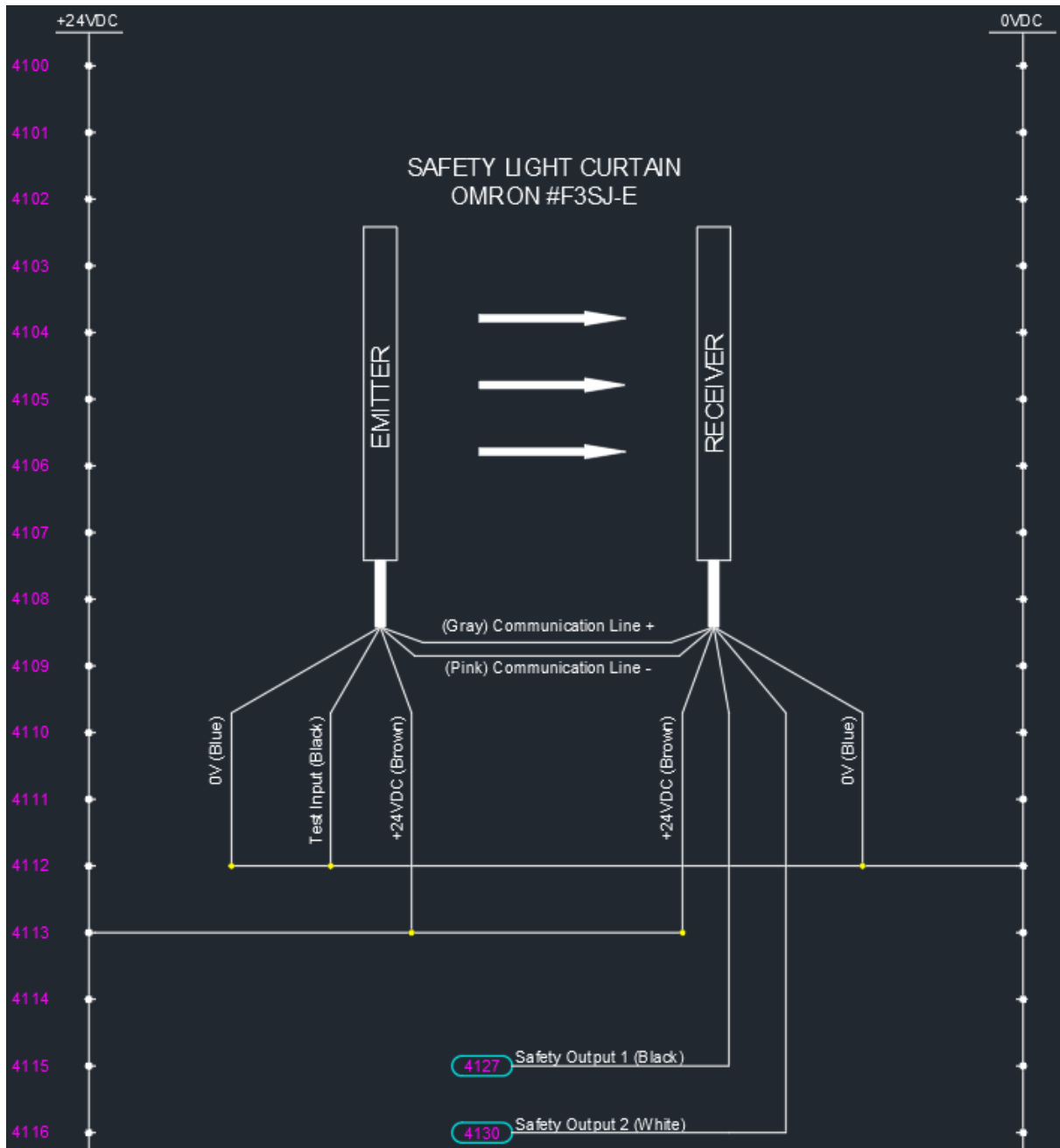

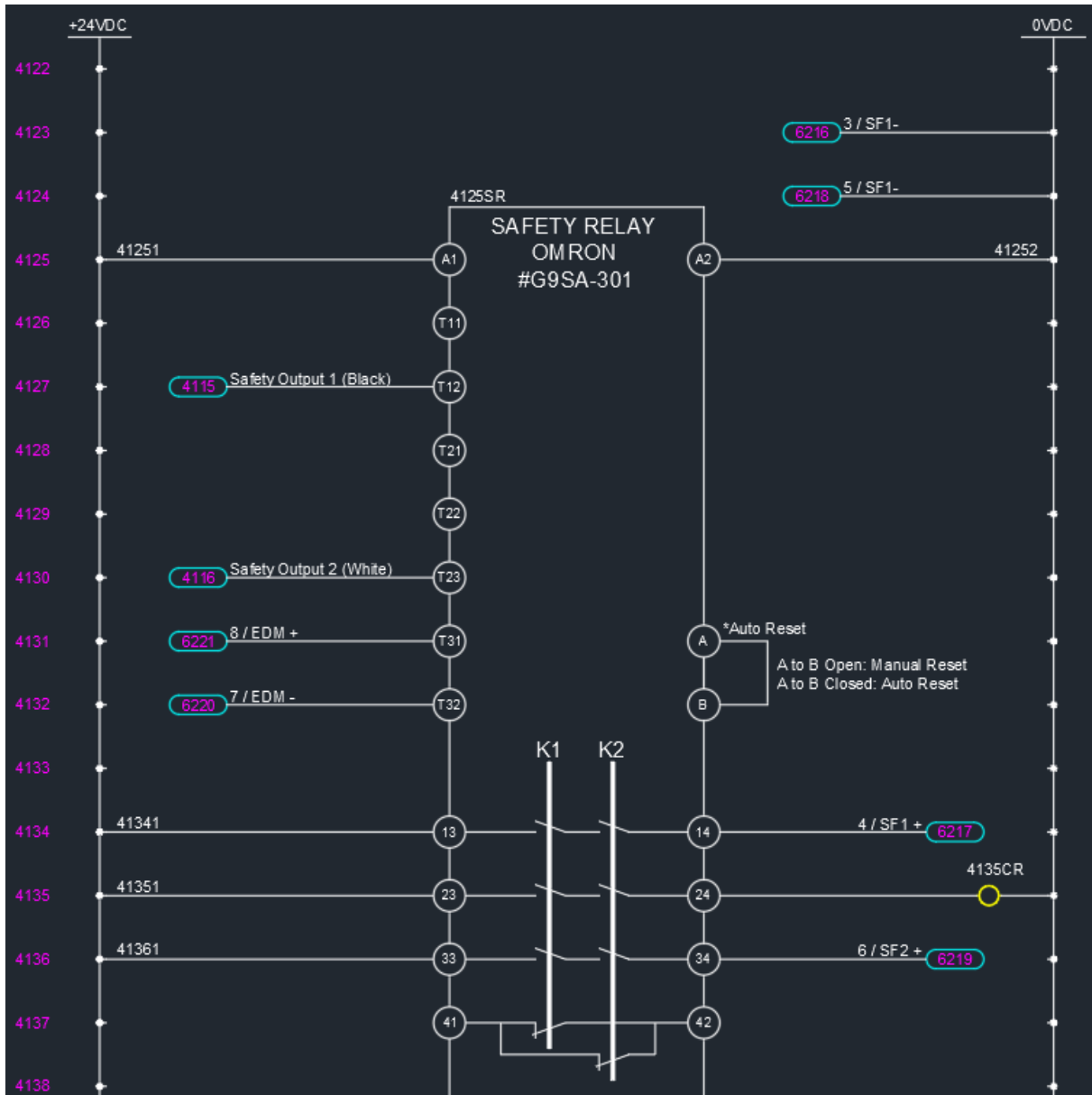

### Servo Drive

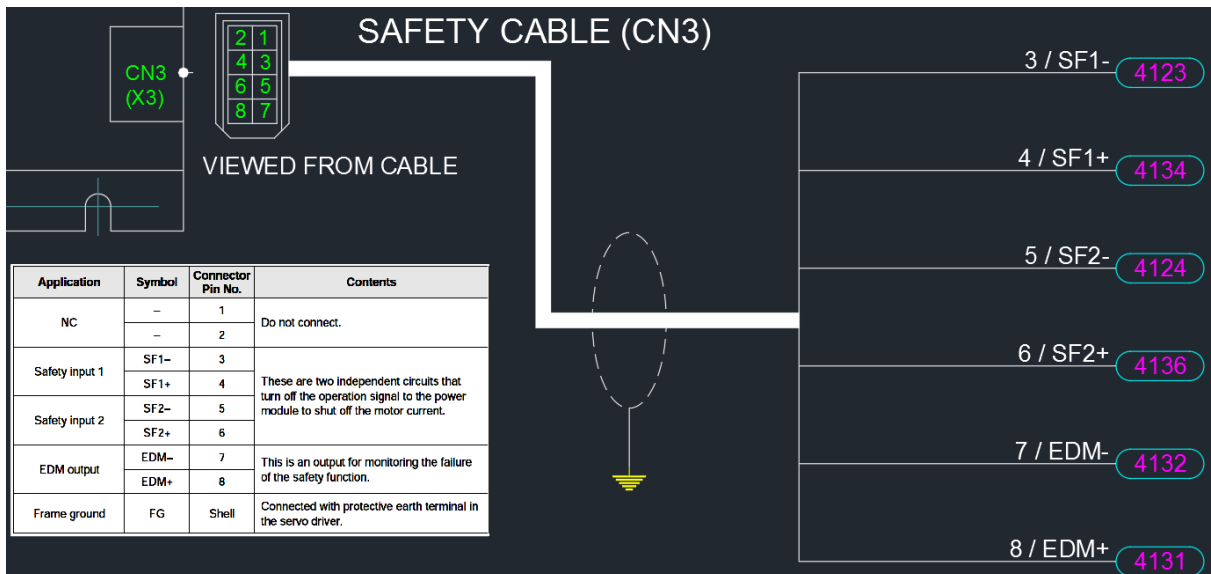

- ✓ Safety circuit example for Cat 4

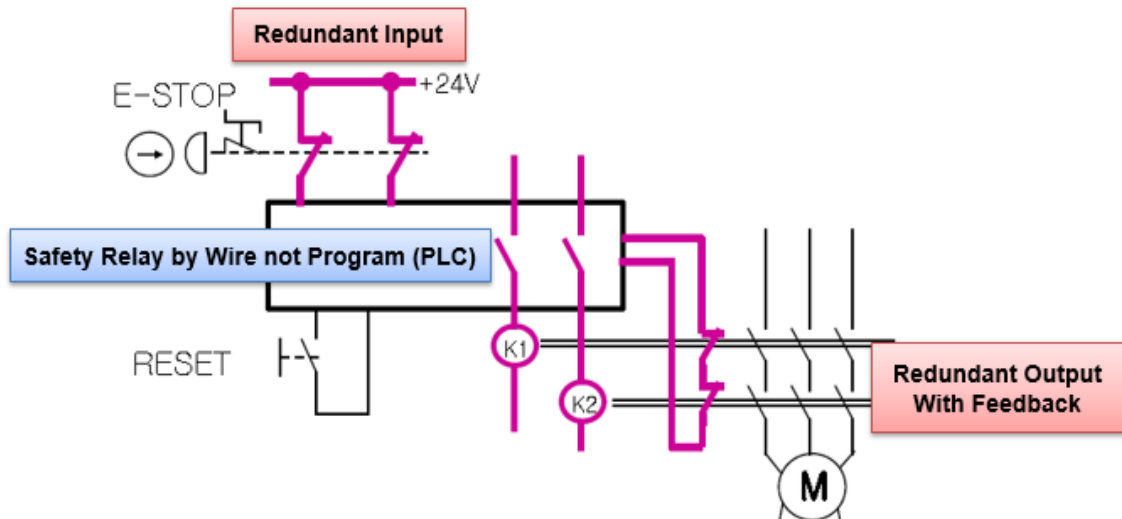

## F. Program Stop Mode

- ✓ Stop Option
  - 0(default), OACIS stops after on-going step is completely done and resumes at the next step
  - 1, OACIS stops on the spot. When it resumes, it restarts the on-going step.
  - 2, It is the same as option1 except that it restarts after resetting motor drive.

- ⚠ ATA will provide Stop and Resume function instead of Emergency Stop.
- ⚠ But this option is not a safety circuit but only a software stop
- ⚠ This circuit does not meet ISO standard safety requirement.
- ⚠ It can cause severe damage to the operator or people who work for maintenance.
- ⚠ So, any kinds of damage caused by this operation is not responsibility of ATA

- ✓ Potential quality related issues with stop and resume function.

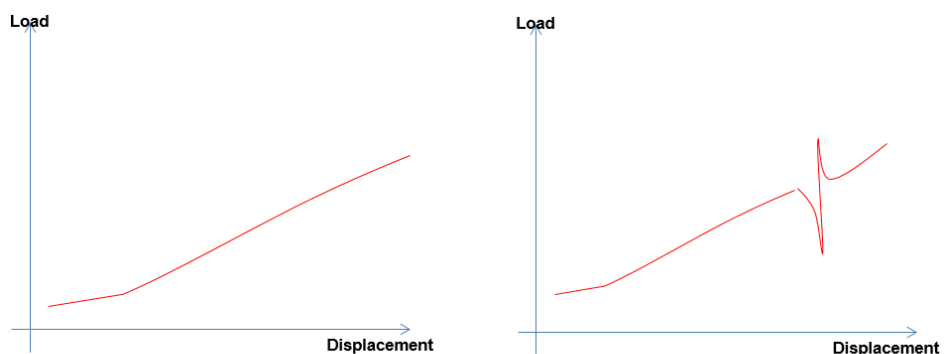

Normal Press Operation

E-Stop -> resume  
There will be abnormal spike.

### III. Software Installation

#### A. Install OACIScom.

- ✓ Double click "...\OACIScom\_v4.01.02.01\setup.exe"

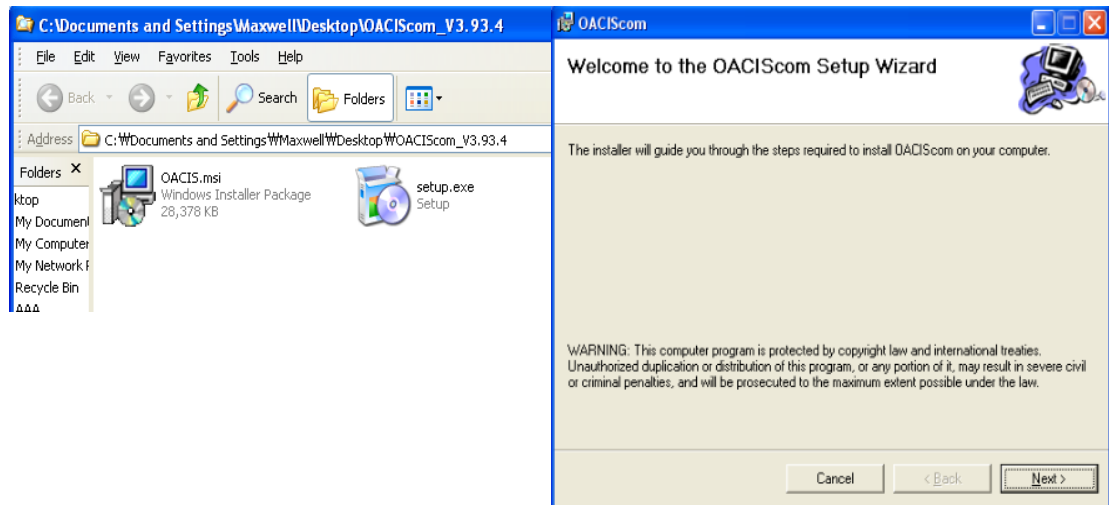

#### B. Special Settings for Window 7

- ✓ Desktop → OACIScom Icon right click → Properties → Compatibility mode check → Privilege Level check

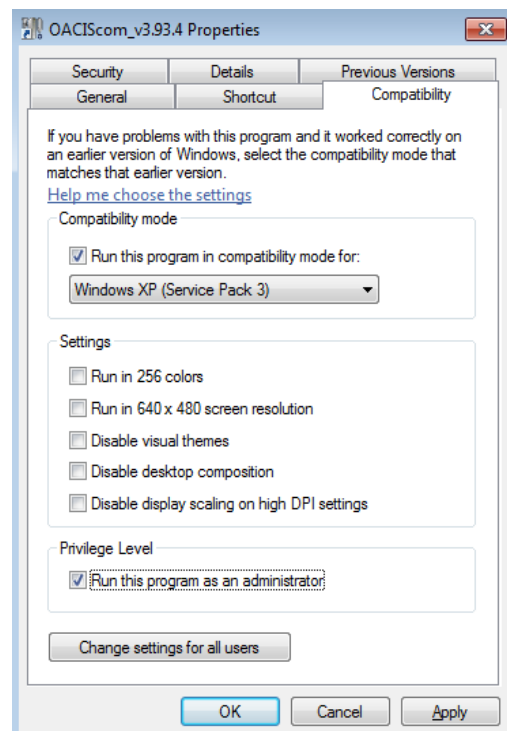
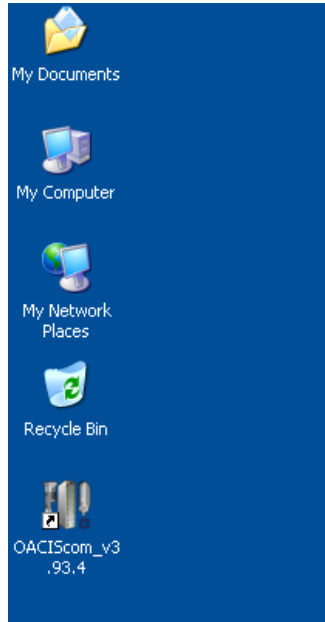

## C. Connect to OACIS.

- ✓ PC IP Address needs to be set properly as shown below.

⚠ It is strongly recommended that the Ethernet cable be directly connected to OACIS without any communication hub. Do not combine the network PLC and OACIS

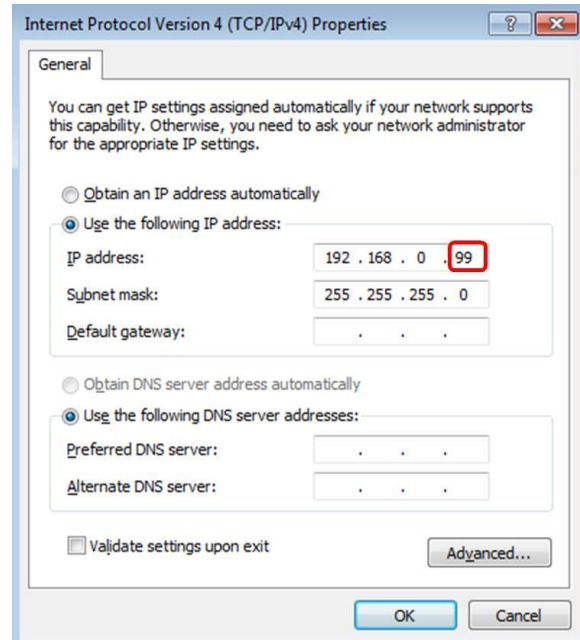

1. This number must be different from OACIS IP address

2. Default OACIS IP address is 192.168.0.3

- ✓ Now, you will see the updated screen with connected status as below.

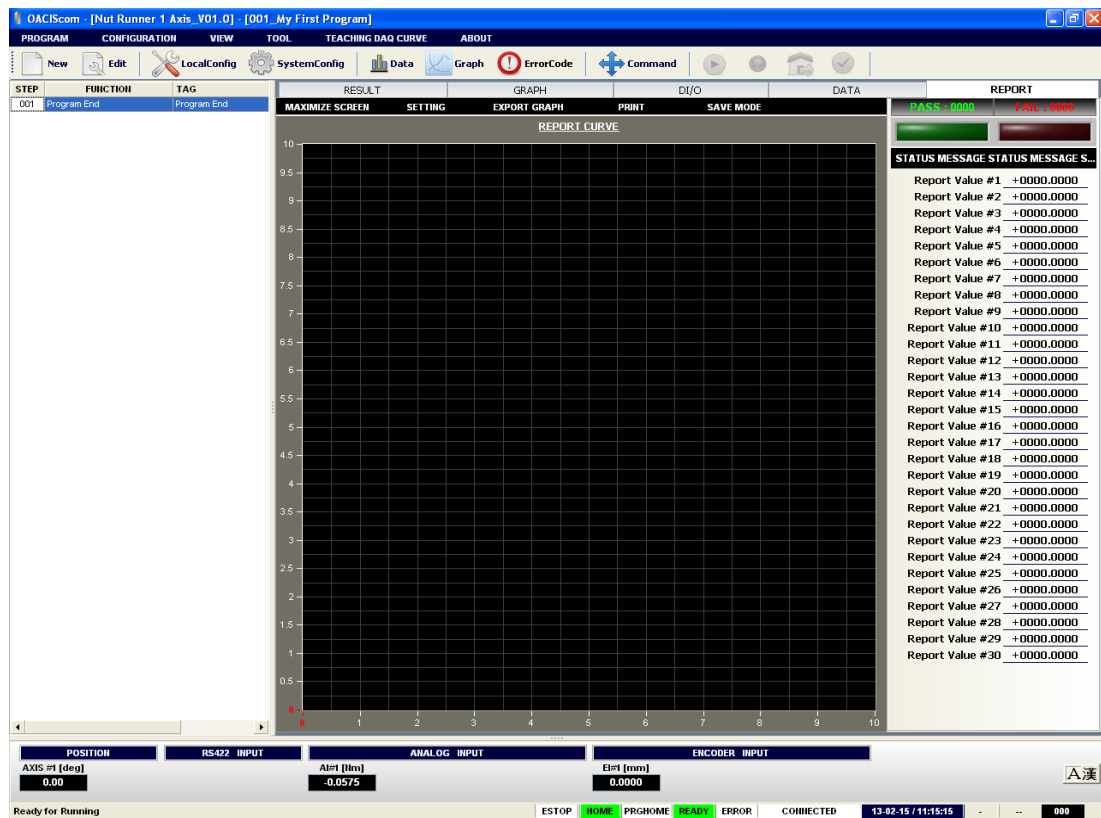

## D. Connect to EtherNet/IP Module



- ✓ EtherNet/IP module IP address needs to be set properly as shown below.
- ✓ Install 'IP Config' application and Run the program.
  - You can download 'IP Config' application from ATA or HMS website, <https://www.anybus.com/support/file-doc-downloads/anybus-support-tools?orderCode=tools>

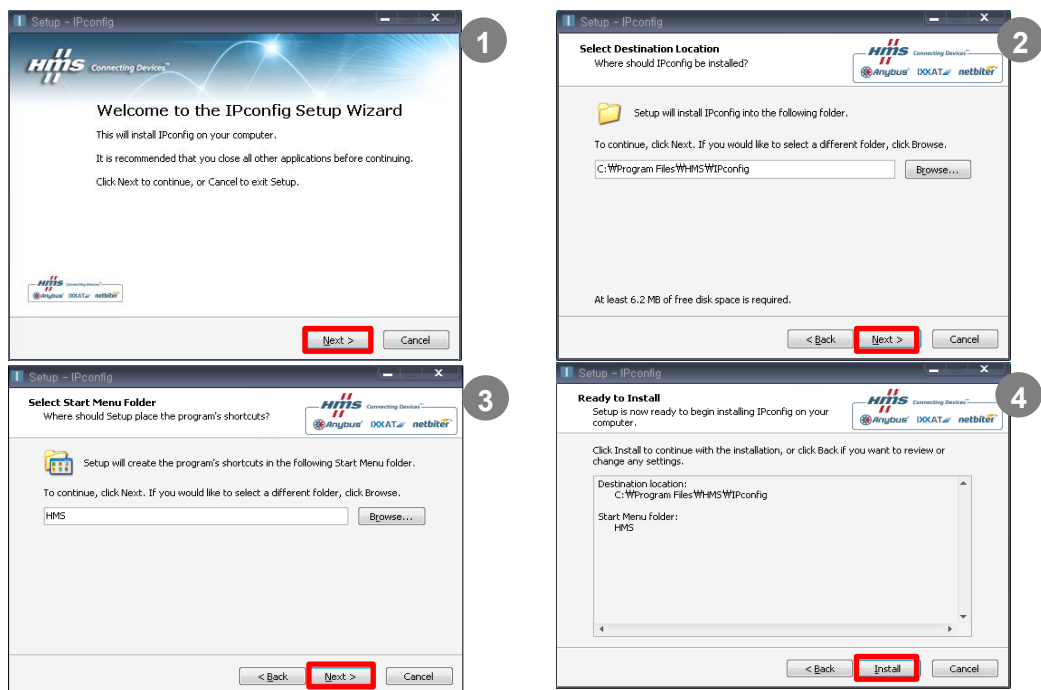

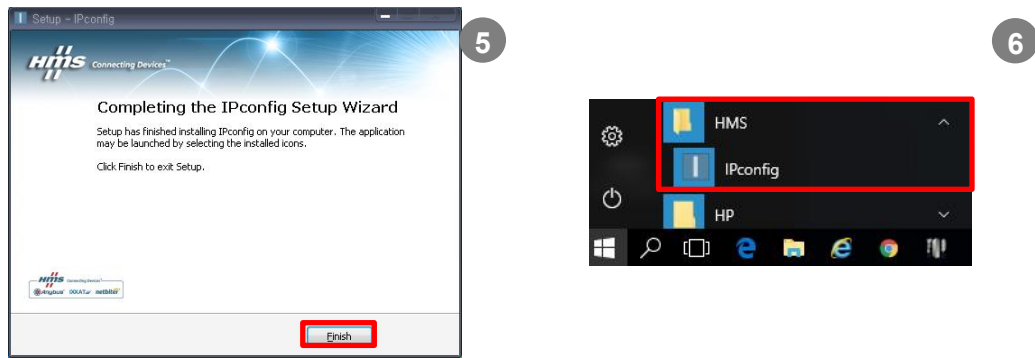

- ✓ Double-click on its entry in the list. And the network information will be updated if you click **Set** after changing IP address and subnet mask properly.

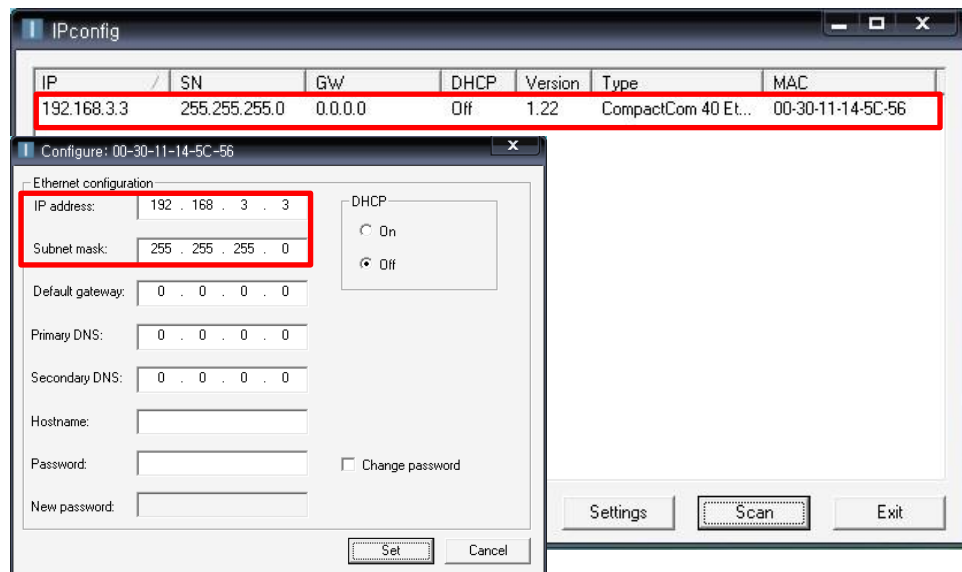

- ✓ Default IP address is **192.168.3.3**
- ✓ When the program runs, the network is automatically scanned for EtherNet/IP module products. The network can be rescanned at any time by clicking **Scan**.

## IV. OACIS Power On

- A. Turn ON the Servo Drive & OACIS power after confirming a proper wiring.



- B. Check up the LoadCell



- ✓ With your hands, please press the shaft of servo press **upward** and **downward**.  
See the value of analog inputs is reasonable.

- C. Confirm the Brake Wiring of Servo Motor.



- ✓ When you press the Reset button, you can see **Servo OK LED** on and hear a snapping **sound of Brake unlocking** in DIO window of OACIScom  
Refer to a brake wiring with a control relay on the next page.

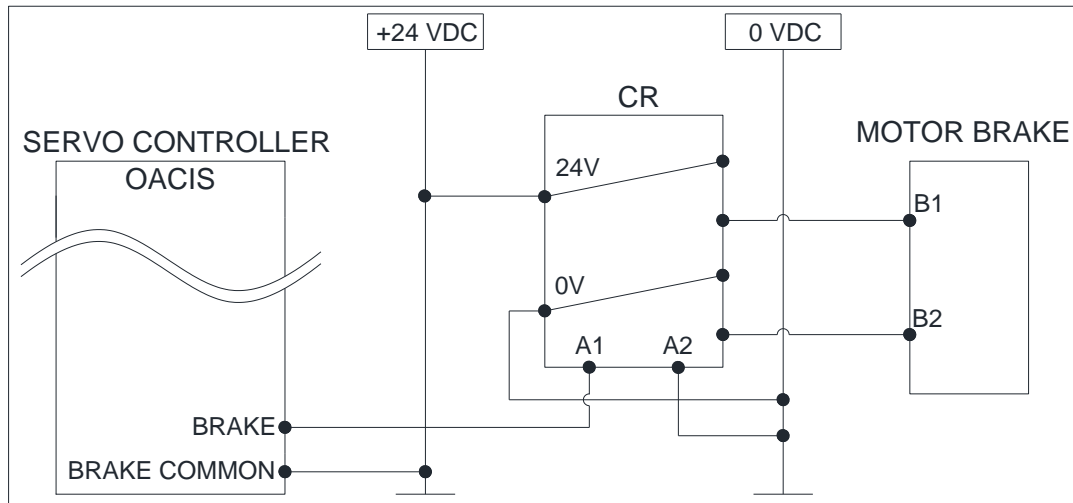

## D. Move Jog.

- ✓ You can move an axis forward or backward manually by operating COMMAND menu. It comes in quite handy when you build the machine up for the first time or some errors happen with high load.
- ✓ You can open “ Command” in Buttons or [TOOL] – [Command] button in the Menu Strip.

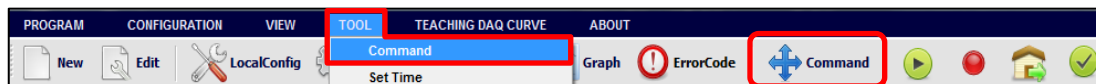

- ✓ Select a proper Axis then you can see “ADVANCE” and “RETRACT” buttons are activated in blue

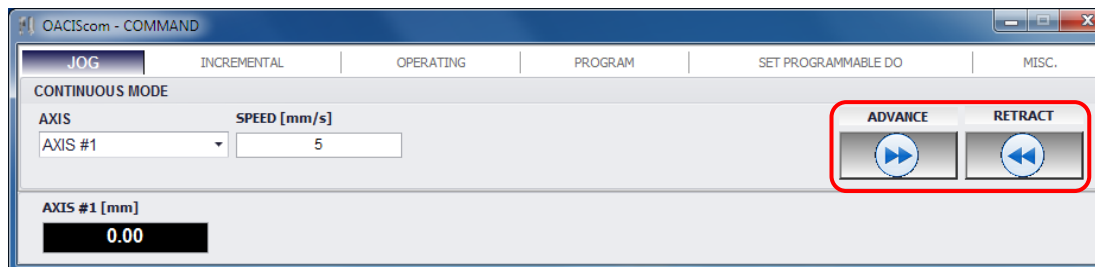

- ⚠ If a **shot pin or air lock system** is installed due to heavy tooling, you should pay attention to jogging. You can make **COMMAND disable** by setting **PROGRAM STOP signal On** when you want to prevent from moving by mistake with locking on.

## E. Homing.

- ✓ Select "OPERATING" tab on the Command window.

