

# OACIS

Open Architecture Control Integrated System

## Installation Instruction for OACIS-1XC

Version 02.02



[www.atainc.com](http://www.atainc.com)

[ata@atainc.com](mailto:ata@atainc.com)

All Rights Reserved

---

## CONTENTS

<b>I. SAFETY INSTRUCTIONS.....</b>	<b>4</b>
<b>II. OACIS OVERVIEW .....</b>	<b>6</b>
A. Part Names .....	6
B. Exterior Dimensions .....	7
<b>III. OACIS POWER IN and GROUND CONNECTIONS .....</b>	<b>8</b>
A. Circuit Diagram .....	8
B. Wiring Example .....	8
<b>IV. DIGITAL INPUT CONNECTIONS .....</b>	<b>9</b>
A. Circuit Diagram .....	9
B. Wiring Example .....	10
<b>V. DIGITAL OUTPUT CONNECTIONS .....</b>	<b>11</b>
A. Circuit Diagram .....	11
<b>VI. ANALOG INPUT CONNECTIONS.....</b>	<b>12</b>
A. Circuit Diagram .....	12
B. Wiring Example .....	13
<b>VII. SERVO CONNECTIONS.....</b>	<b>14</b>
A. Wiring Example .....	14
<b>VIII. JUMPER and SELECTION S/W SETTING.....</b>	<b>17</b>
A. Jumper Settings .....	17
<b>IX. CABLE CONNECTIONS .....</b>	<b>19</b>
A. RS232 Port.....	19
B. Encoder Input Port (Line Driver) .....	20
<b>X. INDUSTRIAL NETWORK MODULE .....</b>	<b>21</b>
A. Overview .....	21
B. Change Industrial Network Module IP Address .....	22
<b>XI. ESTOP CIRCUIT .....</b>	<b>24</b>
A. ESTOP Circuit Diagram .....	24
B. Wiring Example .....	24
C. Precautions for Wiring.....	25
<b>XII. POWER DISSIPATION SPECIFICATIONS .....</b>	<b>26</b>
A. OACIS-1XC : 14 W .....	26
B. PANASONIC A5 Motor Drivers.....	26
<b>REVISION .....</b>	<b>27</b>

## **WARRANTY**



**ATA's exclusive warranty is one year from date of sale by ATA.**

**ATA shall not be responsible for warranty, repair or other claims regarding the products that are not properly handled, stored, installed, operated and maintained per ATA's instructions.**

## I. SAFETY INSTRUCTIONS

Do not install, operate or maintain the OACIS until you have read through this installation manual and related servo drive manuals.

In this manual, the safety levels are classified into “WARNING” and “CAUTION” as below.

 <b>WARNING</b>	<p>Indicates that incorrect handling may cause hazardous conditions resulting in death or severe injury.</p>
 <b>CAUTION</b>	<p>Indicates that incorrect handling may cause hazardous conditions resulting in slight injury to personnel or may cause physical damage to the OACIS.</p>



### WARNING

1. Before wiring or inspection, power off and wait for longer than 5 minutes. And confirm if the voltage level is safe enough. Otherwise, you may get an electric shock.
2. The person who is working for the OACIS especially to wire, inspect and operate, should be fully competent to do the work.
3. Operate the Power In with dry hand. Otherwise, you may get an electric shock.
4. The Cables should not be damaged, stressed or loaded to prevent electric shock.
5. With all covers closed, do Power-On or Operation to prevent electric shock.
6. Except for Jumper Setting, do not remove any covers. Otherwise, you may get an electric shock.
7. Ensure the polarity (+, -) is correct. Otherwise, a burst or damage may occur.
8. Connect Frame GND correctly to prevent severe damage.
9. Do not connect Power In to DI terminal block. It causes severe damage.



## CAUTION

1. Ensure the proper setting in accordance with external device signal type. Otherwise, a burst or damage may occur.
2. Connect the terminals correctly to prevent a burst or damage.
3. Proper Circuit Break is to be installed before Power In to prevent damage.
4. Install the OACIS a load-bearing place.
5. Do not put heavy objects on the OACIS.
6. Use the proper cable between OACIS and Servo Drive ATA provided.
7. Leave specified clearances between the OACIS and enclosure walls.
8. Do not drop or impact the OACIS.
9. Environmental Conditions

	MIN	MAX
Ambient Temperature for Operation	-10°C	+60°C
Ambient Temperature for Storage	-20°C	+70°C
Ambient Humidity	--	90%RH
Ambience	Free from corrosive gas, flammable gas, oil mist, dust and dirt	

## II. OACIS OVERVIEW

### A. Part Names

INSTALLATION AND MAINTENANCE INSTRUCTION

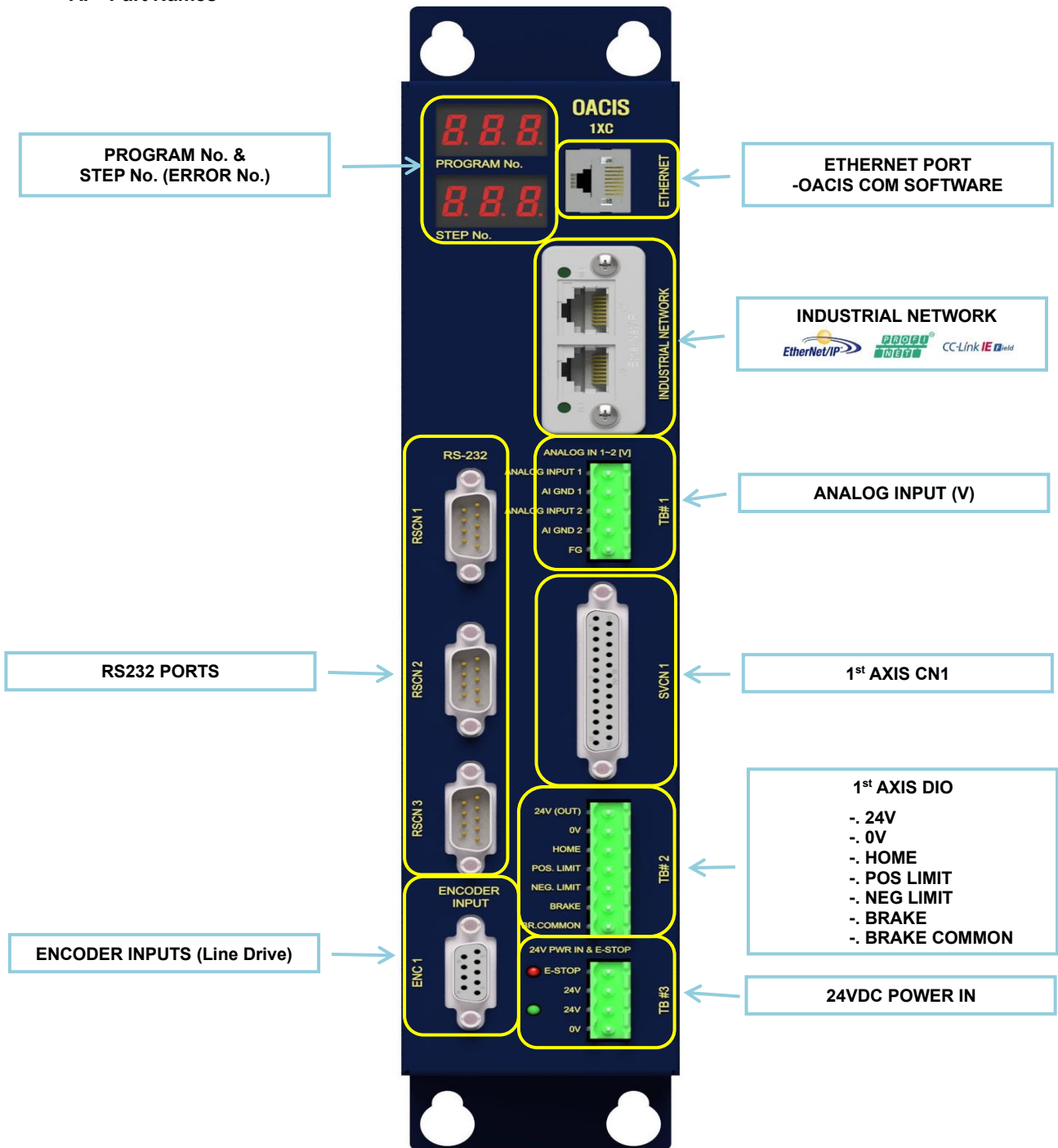

- Ethernet Port: RJ45
- RS232 Port: DSUB 9pin
- RS422 Port: DSUB 15pin
- AXIS CN1: DSUB 25pin
- Encoder Input (Line Drive): DSUB 15pin



### III. OACIS POWER IN and GROUND CONNECTIONS

: TB#3

#### A. Circuit Diagram

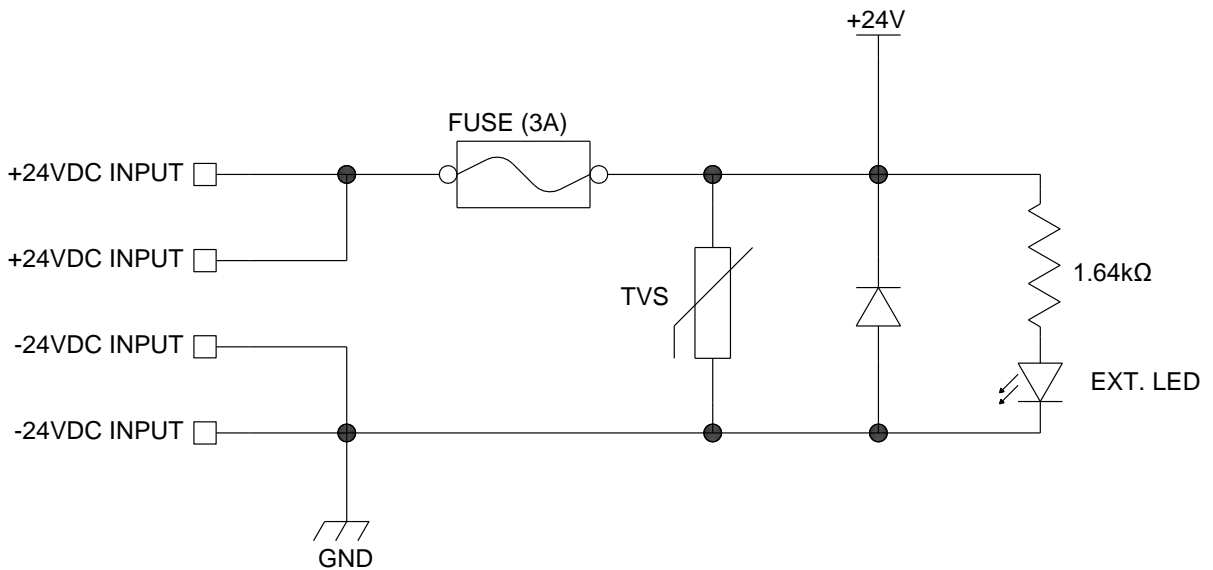

#### B. Wiring Example

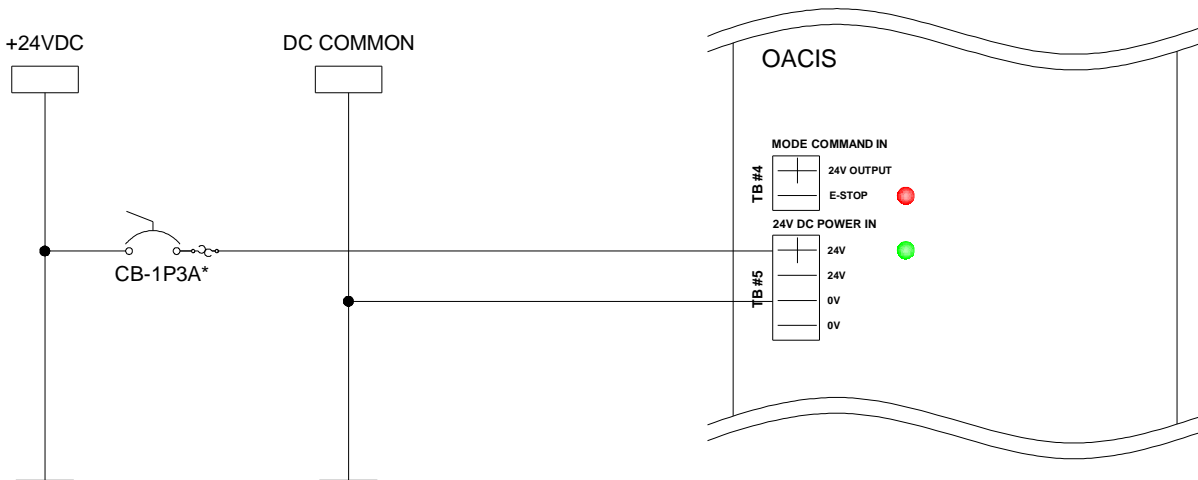

- It is recommended to use proper Circuit Break per the application.
- OACIS itself requires minimum 0.6A (without any connections). It requires more current consumption depending on the application.
- It is recommended to separate Power-In Connection from frequent Turn On and Off circuit like Light Curtain.



### IV. DIGITAL INPUT CONNECTIONS

: TB#2 HOME, POS LIMIT, NEG LIMIT

#### A. Circuit Diagram

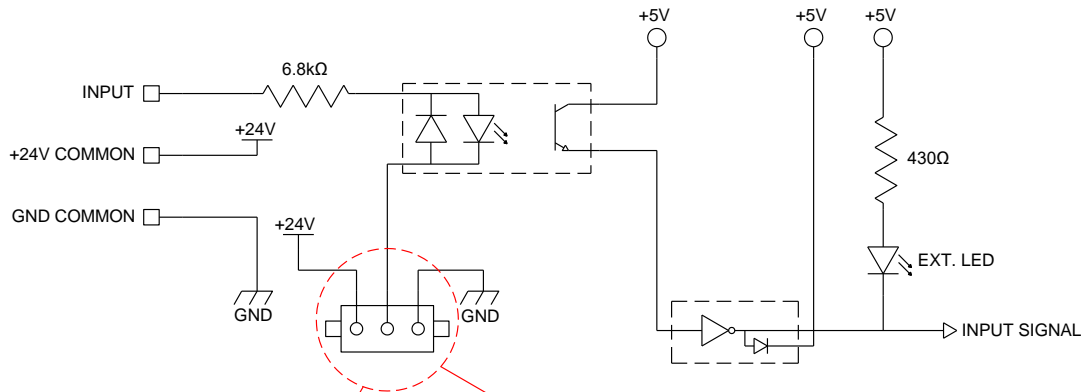

INSTALLATION AND MAINTENANCE INSTRUCTION

#### < NPN TYPE INPUT JUMPER SETTING >

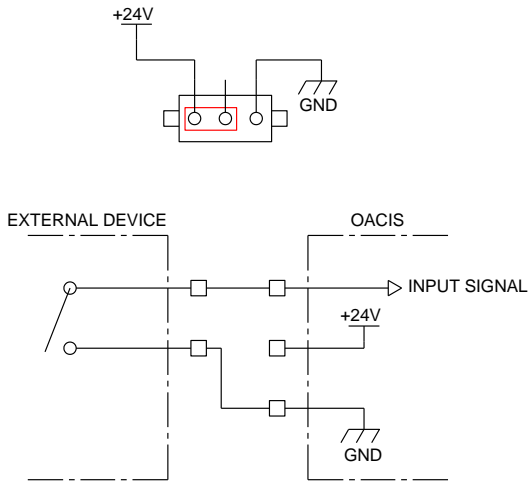

#### < PNP TYPE INPUT JUMPER SETTING >

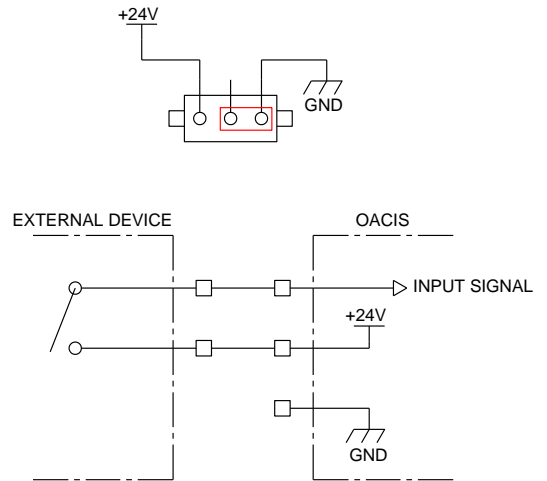

- See the “Chapter VIII” regarding how to set PNP or NPN
- Min. 3.5mA @24VDC is required to switch each channel.
- ⚠ Min. 20VDC is required.
- ⚠ Max. 30VDC is allowed.
- ⚠ Over Voltage input may cause severe damage to OACIS

B. Wiring Example

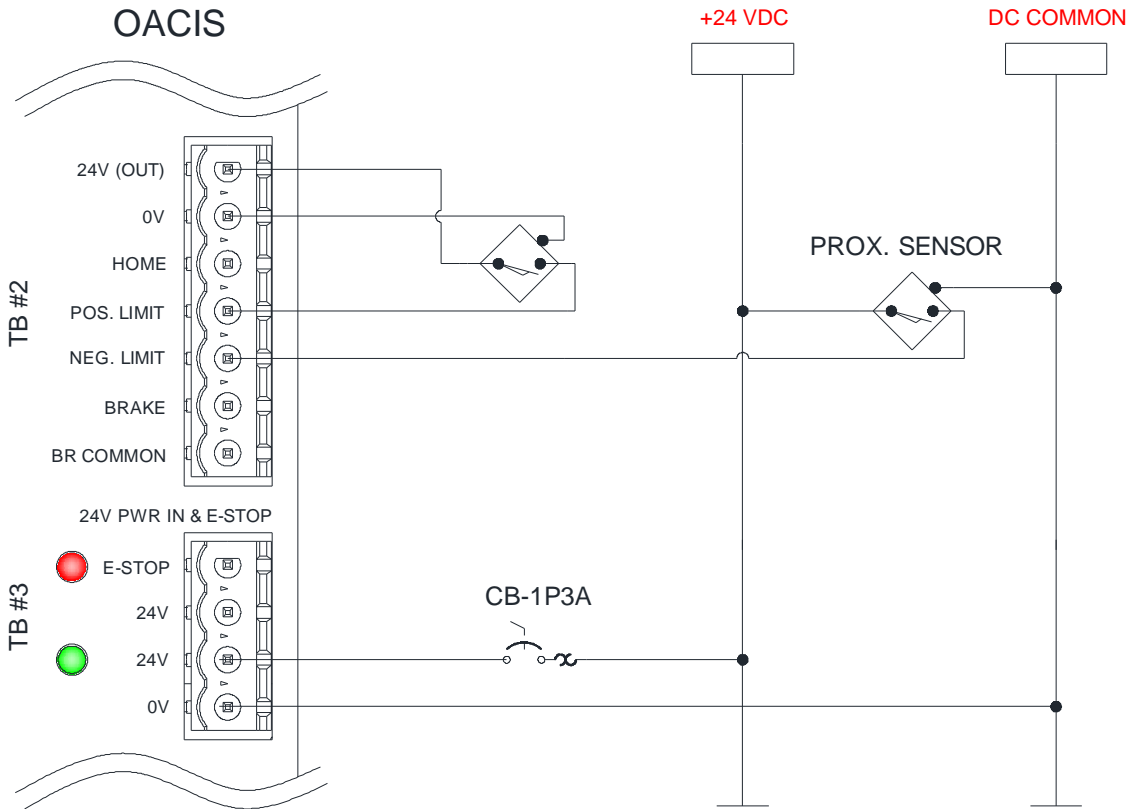

- **⚠️ “24V” channel of Digital Input Terminal Block is “Output”. Do not connect 24V Power Input to this channel. It will cause severe damage of OACIS.**

INSTALLATION AND  
MAINTENANCE  
INSTRUCTION

## V. DIGITAL OUTPUT CONNECTIONS

### : TB#2 BRAKE

#### A. Circuit Diagram

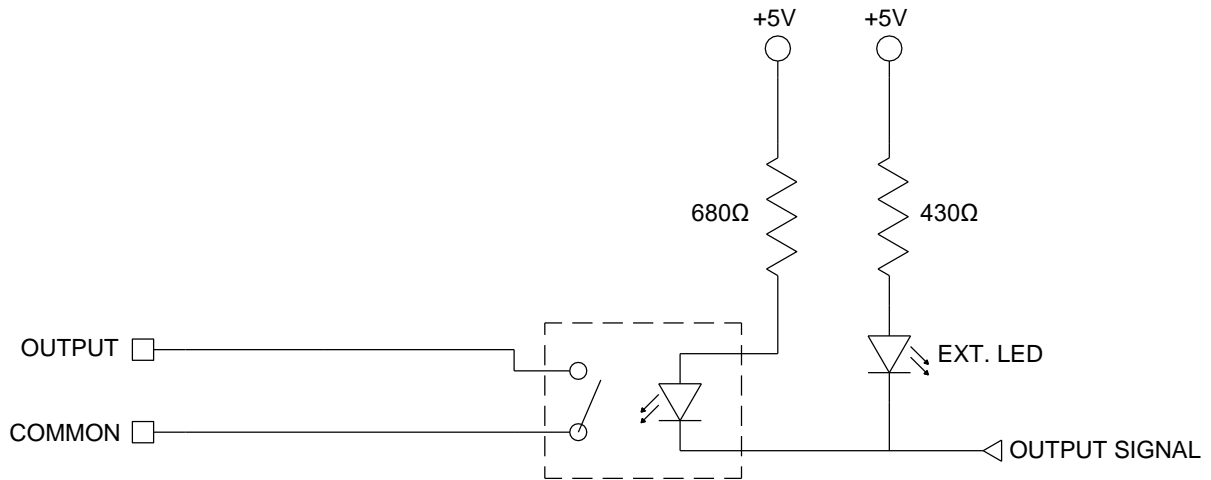

- OACIS provides “TR” type Digital Output Channel.\
- Max Allowable Voltage between ‘Output’ and ‘COMMON’ : 30A
- Max Allowable Current between ‘OUTPUT’ and ‘COMMON’ : 300mA
- ⚠ Over voltage input may cause severe damage to OACIS.

## VI. ANALOG INPUT CONNECTIONS

: TB#1

### A. Circuit Diagram

- CURRENT type Input Setting

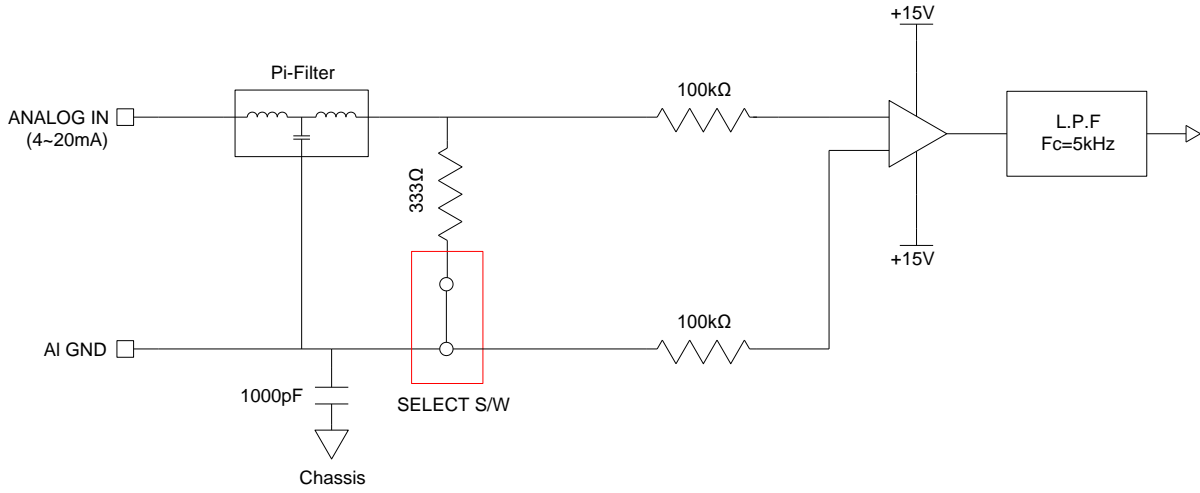

- VOLTAGE type Input Setting

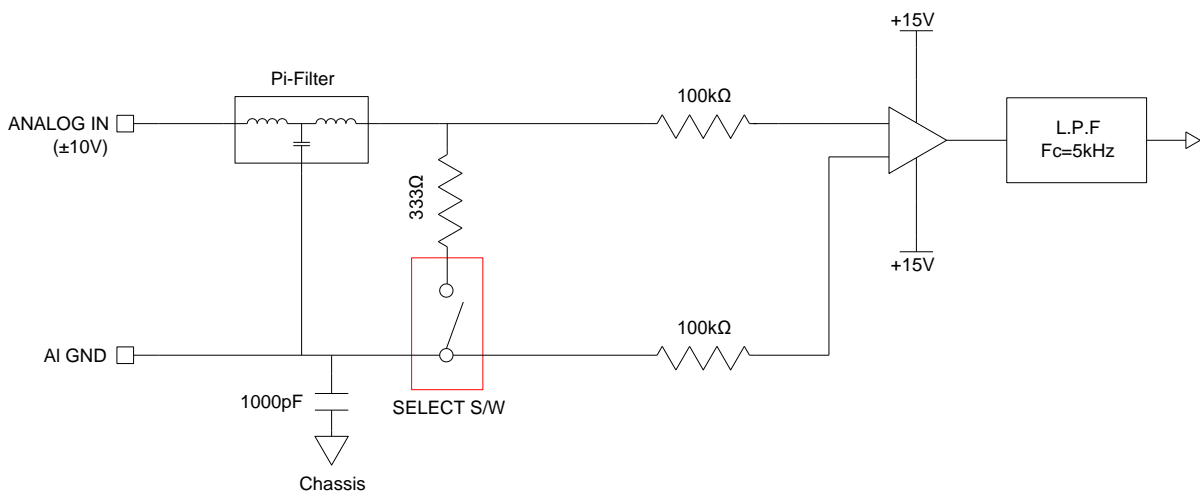

INSTALLATION AND MAINTENANCE INSTRUCTION

B. Wiring Example

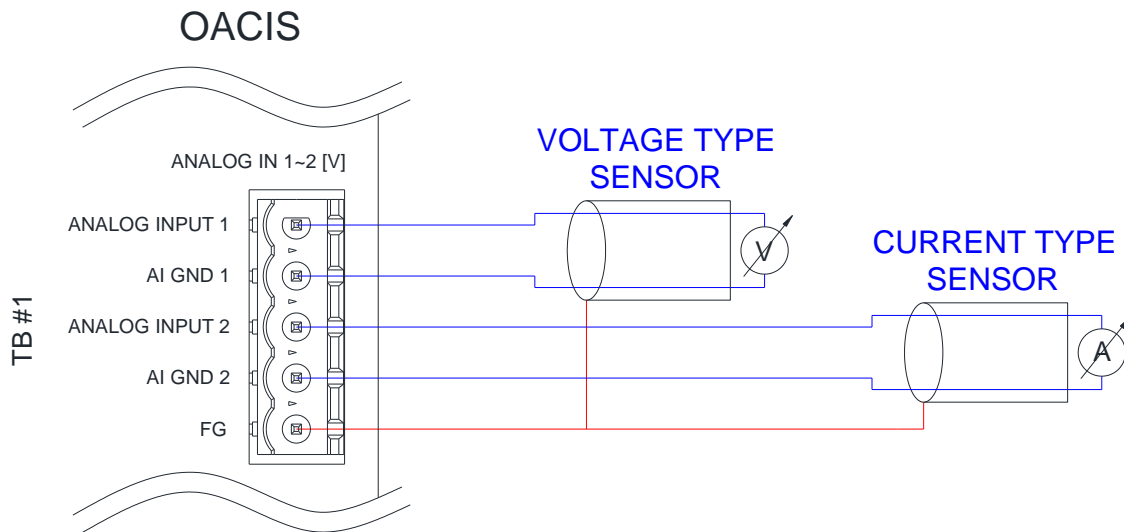

INSTALLATION AND MAINTENANCE INSTRUCTION

- Each Analog Input Channel has its own GND terminal.
- Each Analog Input Channel is reading the signal as differential mode.
- Signal Type Selection Switch needs to be set properly per the input signal type.
  - See the “Chapter VIII” regarding how to set AI signal type.
- Allowable Signal Range:
  - With Voltage Input Setting: -15V ~ +15V
  - With Current Input Setting: -30mA ~ +30mA
- ⚠ OACIS is cutting off the overflowed signal (+/-10V).
- ⚠ Over current or voltage input may cause severe damage to OACIS.
- ⚠ It should be wired to the OACIS Analog Input Channel directly not through any other Terminal Blocks.
- ⚠ The power cable and AMP cable should be separated each other. And shield wires in AMP signal cables should be connected to OACIS chassis ground directly to reduce noise levels.

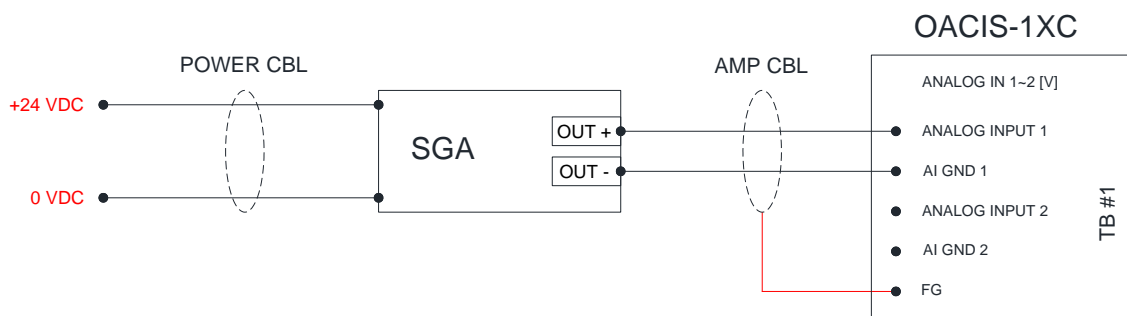

## VII. SERVO CONNECTIONS

### A. Wiring Example

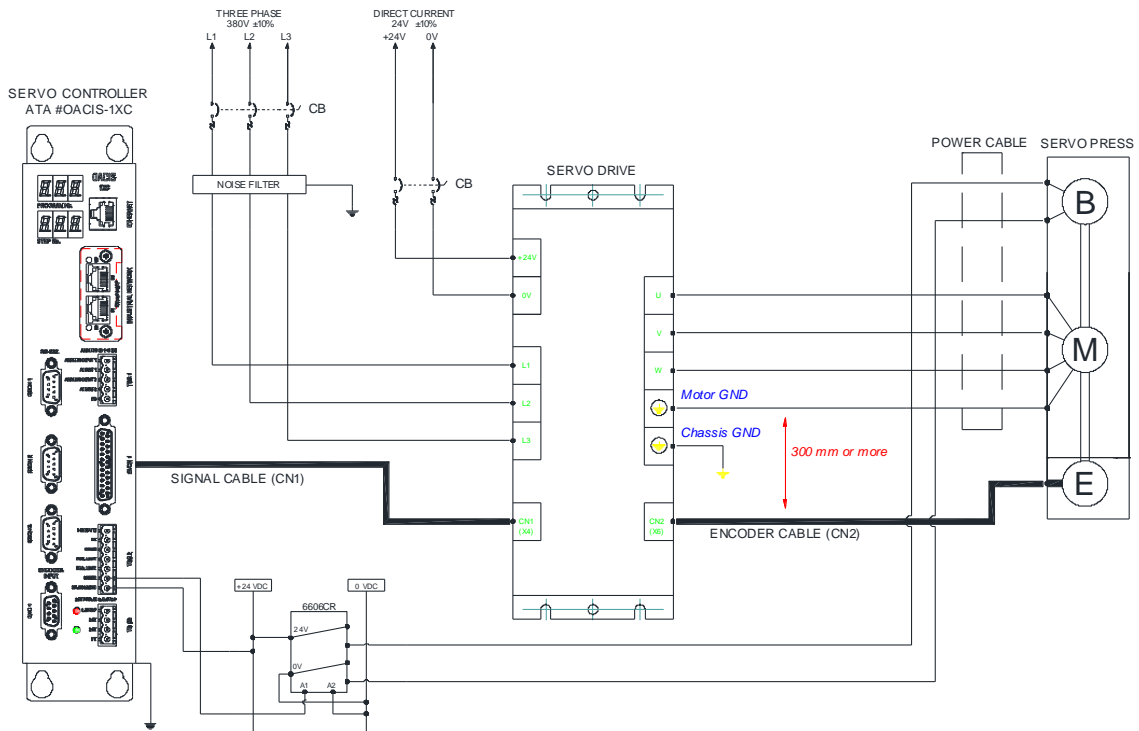

- This wiring example is reference only.
- ⚠ **Max Allowable Voltage between 'BRAKE' and 'COMMON': 30V**
- ⚠ **Max Allowable Current between 'BRAKE' and 'COMMON': 300mA**
- Different Servo Motor requires different circuit. (Consult [ata@atainc.com](mailto:ata@atainc.com))
- You can find detailed wiring example at the [www.atainc.com](http://www.atainc.com)
- PANASONIC A5 Servo is default for OACIS.
- OMRON, LS and Mitsubishi servo system is an option.
- ⚠ **If the noise signal levels are high due to the unexpected electric interference, it can work to clamp a ferrite with U, V and W wires together.**
- In case of installing external regenerative resistors to a servo drive for P200 servo presses, please refer to wiring example

- In case of 3-phase, 400V, G-frame type for P200 servo presses

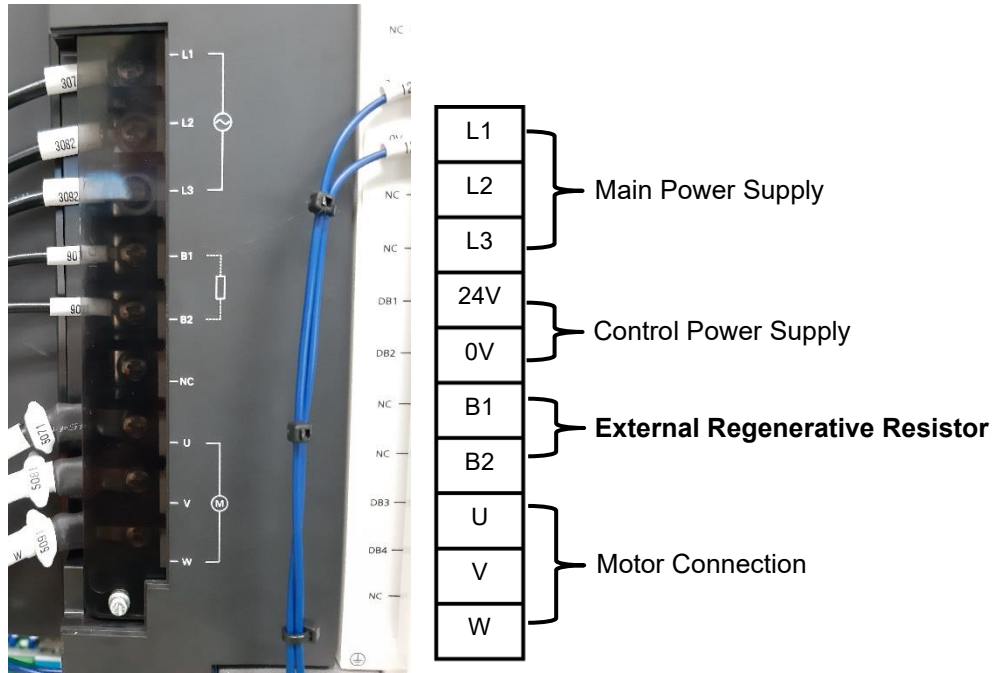

INSTALLATION AND MAINTENANCE INSTRUCTION

**Recommended regenerative resistor**

Frame	Power Supply	
	3 phase, 200V	3 phase, 400V
G	DV0P4285 X 3 in Parallel	DV0PM20049 X 3 in Parallel

Part No.	Specifications				
	Resistance	Cable outside diameter	Weight	Rated power (reference)	
				Free air	With Fan
Ω	mm	kg	W	W	
DV0P4285	20	Φ1.27 AWG18 stranded wire	1.2	52	130
DV0PM20059	80			65	190

- ⚠ **Regenerative resistors get very hot. Install a cooling fan according to the worst running conditions.**
- ⚠ **Avoid the installation near easily accessible place by hand.**
- ⚠ **Install them away from inflammable objects and take preventive measures for fire and burns.**

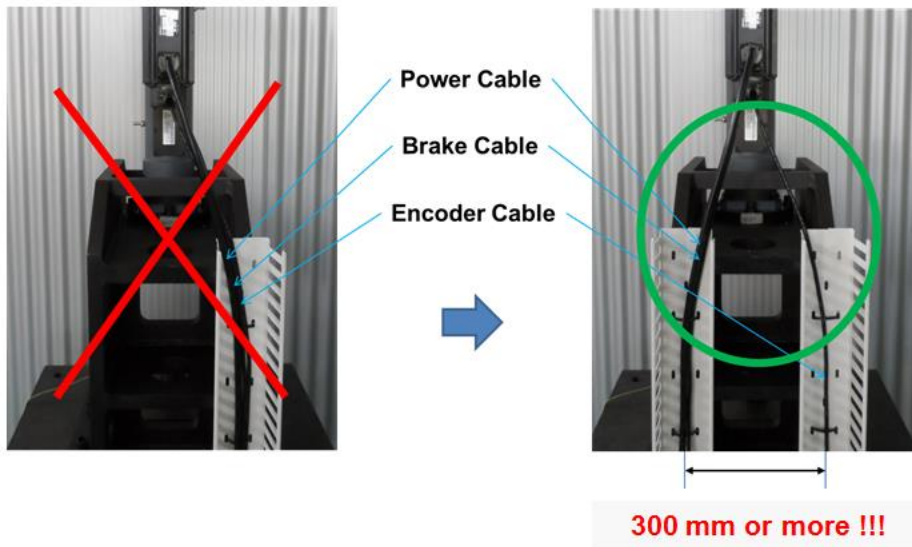
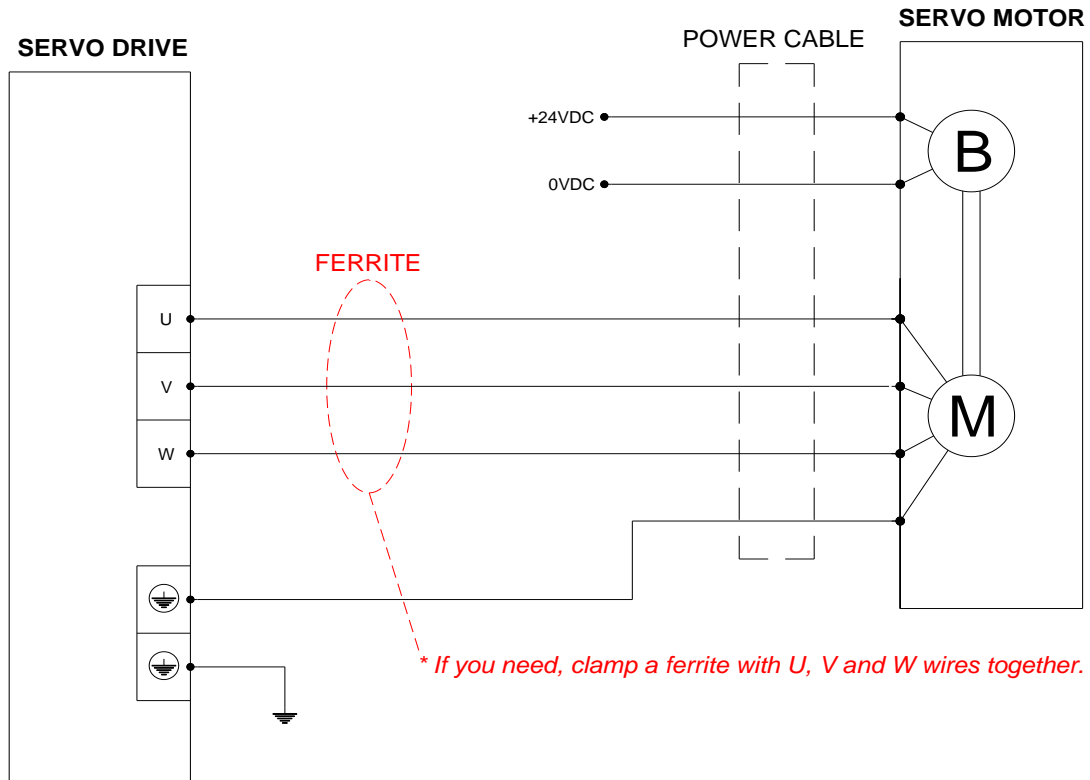

- ⚠ Keep the encoder cable away from the power cable wiring by 300 mm or more. Do not guide the encoder cable through the same duct as the power cable, nor bind them together.
- There are two ground terminals provided on the driver. One of them must be connected to the ground terminal of the control panel and the other is for the motor ground.
- ⚠ The ground terminal must not be shared with other equipment.
- ⚠ Overall pay particular attention to miswiring especially in power input and motor output, ground or loose connection.
- Contact ATAinc for more details.



### VIII. JUMPER and SELECTION S/W SETTING

#### A. Jumper Settings

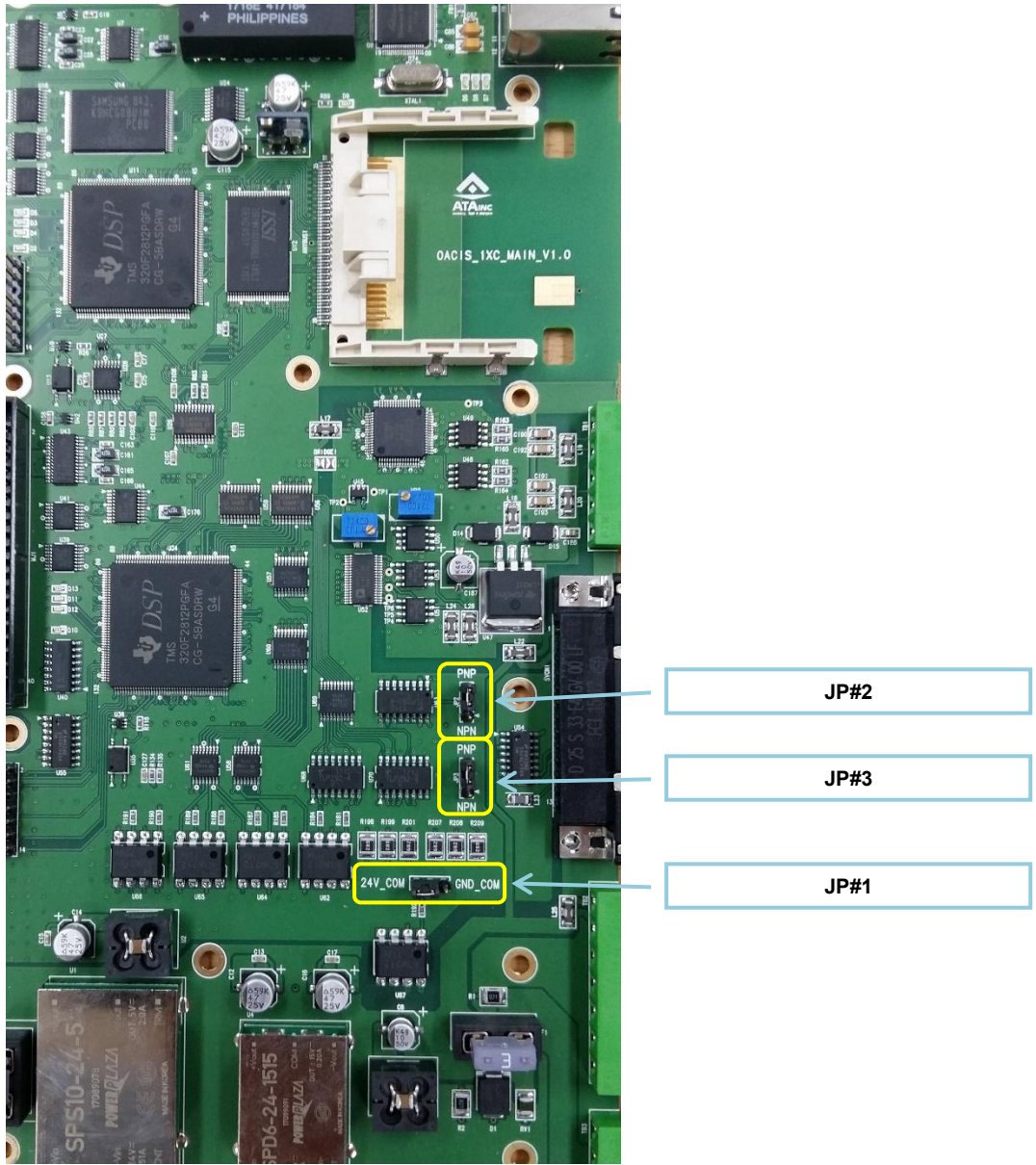

INSTALLATION AND  
MAINTENANCE  
INSTRUCTION

● **JP#1: AXIS1 CN1 Cable (TB#4) DI/O Signal Type**

- It is to be used to set DO signal type in CN1 Cable. If the servo drive is using PNP type signal, it should be set as "24V" else if the signal is NPN, it should be "GND".
- Default OACIS DI in CN1 is set as NPN (SINK)

For SOURCE I/O Interface / PNP  
OACIS Output : 24VDC or Open  
24V

For SINK I/O Interface / NPN  
OACIS Output : 0VDC or Open  
GND

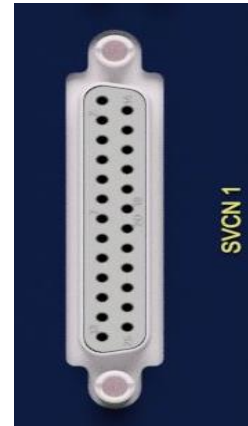
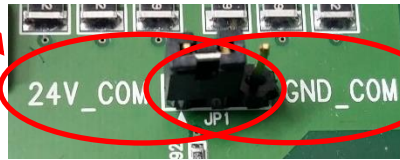

● **JP#2: 24V PWR IN & E-STOP (TB#3) Digital Input Signal Type.**



● **JP#3: AXIS1 (TB#2) Home, Positive Limit and Negative Limit Sensors Signal Type**

- One Jumper is to be used to set all Channels.

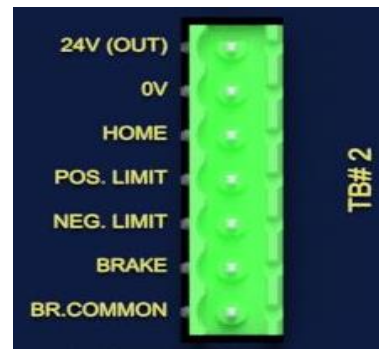

## IX. CABLE CONNECTIONS

### A. RS232 Port

- Port Type: DSUB 9pin Male Connector

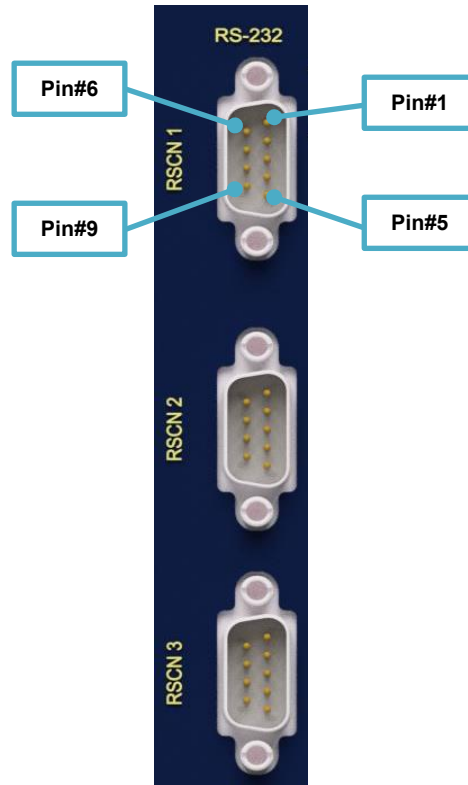

INSTALLATION AND MAINTENANCE INSTRUCTION

- Pin Assignment

PIN No.	PIN ASSIGNMENT	PIN No.	PIN ASSIGNMENT
1	No Connection	6	No Connection
2	RXD (OACIS IN)	7	No Connection
3	TXD (OACIS OUT)	8	No Connection
4	No Connection	9	Shield
5	GND		

**⚠️ Only Pin #2, #3 and #5 need to be connected properly. Connection of other pins(#1, #4, #6, #7 and #8) is not allowed.**

- Enable Ports by Mode

Mode	Serial Communication	RSCN 1	RSCN 2	RSCN 3
Normal <sup>1)</sup>	O	O	O	X
Firmware <sup>2)</sup>	X	MAIN CPU	X	CTRL CPU

**⚠️ If OACIS is in firmware mode, OACIS will not run.**

1) See the Manual "How to Config → APPENDIX #1"  
 2) See the Manual "MISC → How to Update Firmware"

### B. Encoder Input Port (Line Driver)

- This port is for A/B/Z Phase Voltage Differential Line Driver Output.
- Compliant with RS-422
- Port Type: DSUB 9pin Female Connector

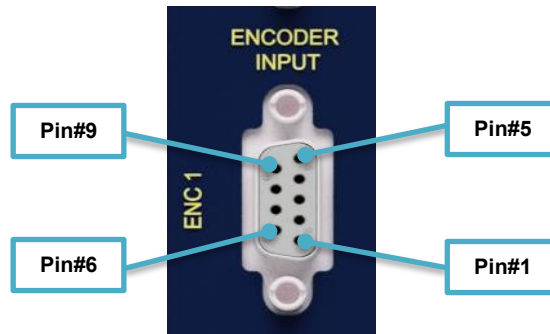

- **Pin Assignment**

OACIS DSUB 9PIN	
Pin #	Description
1	+Vcc (5V)
2	0V
3	A
4	/A
5	B
6	/B
7	Z
8	/Z
9	Shield

## X. INDUSTRIAL NETWORK MODULE

### A. Overview

- The industrial network communication module provides with one of EtherNet/IP, ProfiNet and CC-Link IE.
- The module supports both linear and ring network topology.

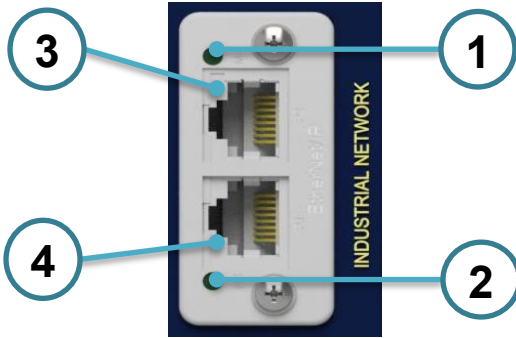

#	Item	Connector
1	Network Status LED	Ethernet, RJ45
2	Module Status LED	
3	Link/Activity LED (port 1)	
4	Link/Activity LED (port 2)	

- Test sequences are performed on the network and Module Status LEDs during startup.

INSTALLATION AND MAINTENANCE INSTRUCTION

#### ● Network Status LED

LED State	Description
Off	No power or no IP address
Green	Online, one or more connections established (CIP Class 1 or 3)
Green, flashing	Online, no connections established
Red	Duplicate IP address, FATAL error
Red, flashing	One or more connections timed out (CIP Class 1 or 3)

#### ● Module Status LED

LED State	Description
Off	No power
Green	Controlled by a Scanner in Run state
Green, flashing	Not configured, or Scanner in Idle state
Red	Major fault (EXCEPTION-state, FATAL error etc.)
Red, flashing	Recoverable fault(s). Module is configured, but stored parameters differ from currently used parameters.

#### ※ Recommended wiring example

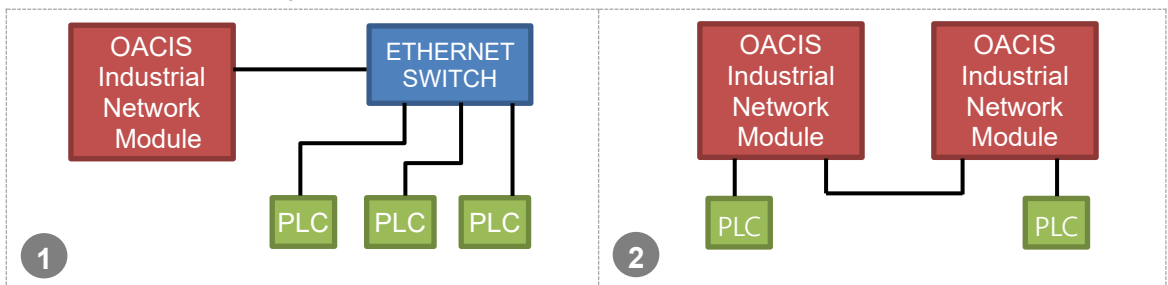

**B. Change Industrial Network Module IP Address**



1. Connect OACIS-1XC industrial network module to PC via ethernet cable.
2. Install 'IP Config' application and Run the application
  - ✓ You can download 'IP Config' program from ATA or HMS website and install it, <https://www.anybus.com/support/file-doc-downloads/anybus-support-tools?orderCode=tools>

<p>1</p>	<p>2</p>
<p>3</p>	<p>4</p>
<p>5</p>	<p>6</p>

INSTALLATION AND MAINTENANCE INSTRUCTION

3. Double-click on its entry in the list. And the network information is updated if you click **Set** after changing IP address and subnet mask.
  - ✓ Default IP address is **192.168.3.3**
  - ✓ When the program runs, the network is automatically scanned for EtherNet/IP module products.  
The network can be rescanned at any time by clicking **Scan**

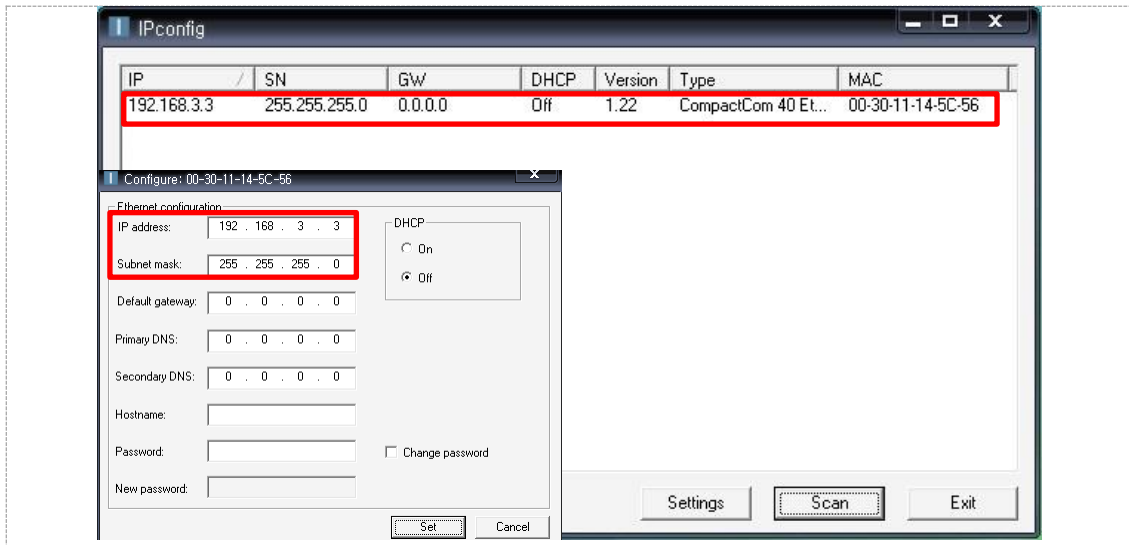

## XI. ESTOP CIRCUIT

### A. ESTOP Circuit Diagram

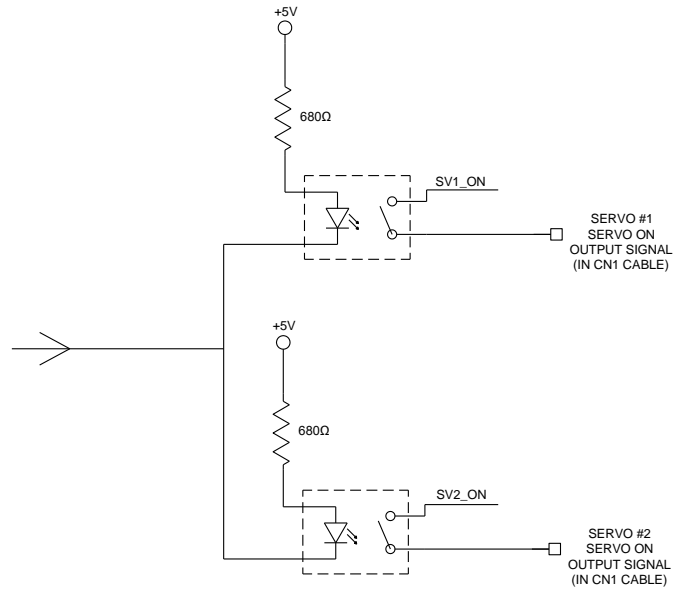
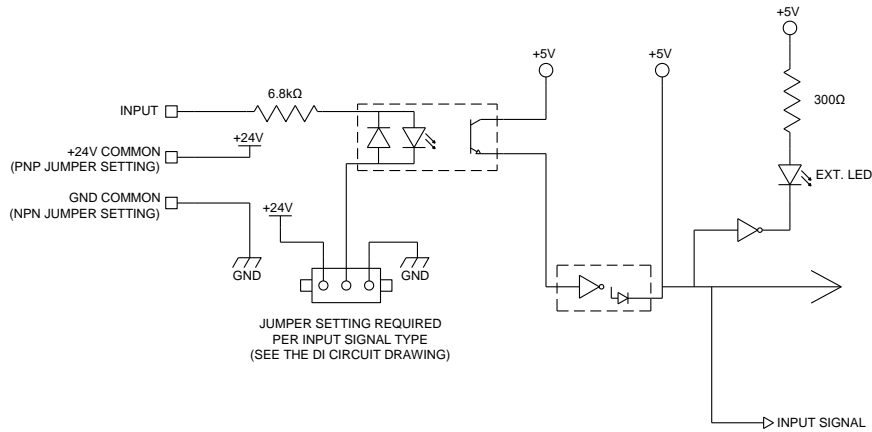

### B. Wiring Example

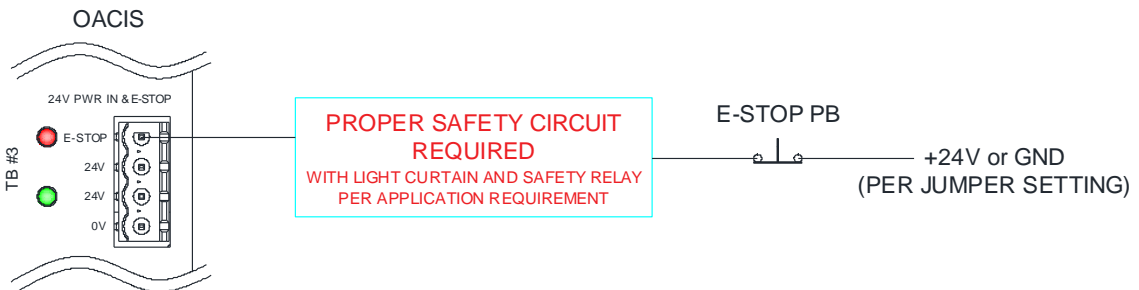



C. Precautions for Wiring

- You need to install the same control relay onto SF1+, SF2+ and E-STOP signal respectively when safety outputs are pulse-type signals and there is no AUX output in the safety relay of STO safety circuit.

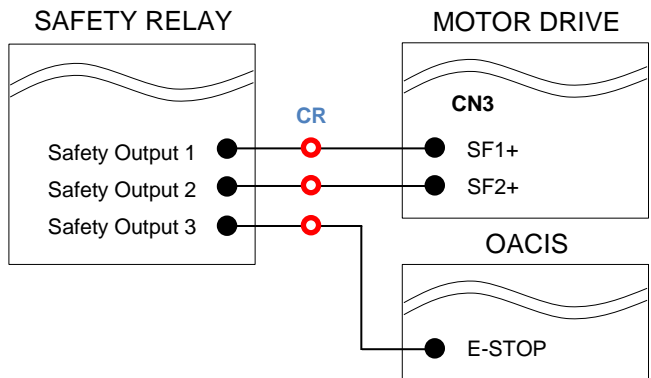

- You need to connect E-STOP to AUX output when safety outputs are pulse-type signals and there is an AUX output in the safety relay of STO safety circuit.

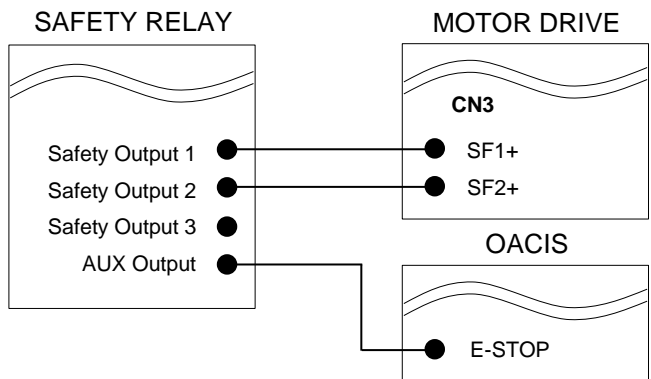

INSTALLATION AND MAINTENANCE INSTRUCTION

## XII. POWER DISSIPATION SPECIFICATIONS

### A. OACIS-1XC : 14 W

### B. PANASONIC A5 Motor Drivers

#### Servo Presses

Motor Model	Drive				
	Model	Phase, $\phi$	Input Voltage, V	Power Output, kW	Power Dissipation, W
MSMD022G1	MADHT1507	1	220	0.2	33
MSMD042G1	MBDHT2510	1	220	0.4	36
MSME102G1	MDDHT5540	3	220	1.0	55
MSME202G1	MEDHT7364	3	220	2.0	116
MSME302G1	MEDHTA390	3	220	3.0	218
MSME402G1	MFDHTB3A2	3	220	4.0	214
MSME502G1	MFDHTB3A2	3	220	5.0	340
MSME104G1	MDDHT3420	3	380	1.0	55
MSME204G1	MEDHT4430	3	380	2.0	74
MSME304G1	MFDHT5440	3	380	3.0	120
MSME404G1	MFDHTA464	3	380	4.0	138
MSME504G1	MFDHTA464	3	380	5.0	212

#### Nut Runners

Motor Model	Drive				
	Model	Phase, $\phi$	Input Voltage, V	Power Output, kW	Power Dissipation, W
MSMD012G1S	MADHT1505	1	220	0.1	26
MSMD022G1S	MADHT1507	1	220	0.2	33
MSMD042G1S	MBDHT2510	1	220	0.4	36
MSMD082G1S	MCDHT3520	3	220	0.75	39

**REVISION**

**v01.00: Engineering Released**

**v01.01(Jul. 4, 2017)**

- Circuit Diagram changed in III, IV
- Wiring Example deleted in V
- Wiring Example picture changed in VI
- Misspelling in VIII revised
- Power Dissipation Specifications updated

**v01.02(Aug. 12, 2017)**

- Added information in IX, X

**v01.03(Aug. 17, 2017)**

- Wiring Example picture changed in VII

**v01.04(Aug. 18, 2017)**

- Mistyping Modified

**v01.04(Aug. 18, 2017)**

- Mistyping Modified

**v02.00(May. 23, 2018)**

- OACIS-1XC released
- Page format Updated

**v02.01(May. 13, 2020)**

- Duplicated content deleted in IX.B
- Wiring example for external regenerative resistors Added in VII

**v02.02(Jan. 26, 2021)**

- Precautions for wiring added in XI.C